



**Electric Engineering Division**

**RULES AND REGULATIONS  
FOR CONDUIT INSTALLATION  
(COMMERCIAL & RESIDENTIAL)**

**LATEST REVISION: 08/23/2023**



1805 NE 30th Ave., Bldg. 400  
Ocala, FL 34470-4875  
Phone: (352) 351-6620  
Fax: (352) 401-6961

---

**Electric Engineering Division**

Dear Developer:

Over the next few months, the City of Ocala Electric Utility (OEU) will be working closely with you and your contractors to install the electrical conduit system for your project. We in the Electric Engineering Division are looking forward to working with you and your contractors and want the installation to proceed as smoothly as possible.

Attached, please find the OEU Rules and Regulations for Conduit Installation to be referenced by your electrical conduit contractor. If the contractor has any questions that are not addressed in this guide, please contact the OEU representative responsible for the project.

Respectfully,

Ocala Electric Utility  
Electric Engineering Division

## TABLE OF CONTENTS

	<u>PAGE</u>
A. TABLE OF CONTENTS .....	3
B. TERMS AND DEFINITIONS .....	5
C. DEVELOPER’S RESPONSIBILITIES .....	7
D. TRENCH SPECIFICATIONS AND PROCEDURES .....	8
E. REQUIREMENTS FOR JOINT USE OF TRENCH .....	9
F. CONDUIT SPECIFICATIONS .....	10
G. CONDUIT PROCEDURES	
1. RACEWAYS .....	11
2. RISER STUB-UPS .....	12
3. TRANSFORMER LOCATIONS .....	12
4. PRIMARY CABINET LOCATIONS .....	12
H. SUMMARY .....	13
I. SYMBOLS .....	14
J. EXHIBITS	
1. Typical Riser Pole Stub-up .....	15
2. Concrete Encasement and Support Placement .....	16
3. Typical Trench Line w/ Respect to Right-of-Way .....	17
4. Typical 1-phase Transformer Location .....	18
5. Typical 3-phase Transformer Location .....	19
6. Typical 1-phase Primary Cabinet Location .....	20
7. Typical 3-phase Primary Cabinet Location (Exhibits A & B) .....	21
8. Conduit Stub-up End Requirements .....	23
9. 1-phase Transformer Conduit Placement in Easement .....	24
10. Warning Tape Placement .....	25
11. Minimum Clearance (Cable TV, Internet, Telephone) .....	26
12. Minimum Clearance (Water, Sewer, Gas) .....	27
13. Minimum Horizontal Clearance Around Equipment .....	28
14. Typical Street Light Vault Location .....	29
15. Typical Secondary Pedestal Location .....	30
16. Typical Secondary Vault Location .....	31
17. Service Stub-outs at Transformer (Future Use) .....	32
18. Temporary Service at Transformer or Secondary Vault .....	33
19. Multiple Conduits in Trench .....	34
20. SDR-13.5 or HDPE Flexible Bore Pipe Stub-ups .....	35
21. Meter Socket Spacing Requirements .....	36
22. Acceptable URD Combination Meter Socket w/ Breaker Panel .....	37
23. Secondary/Service Conduit Installation from Riser Pole .....	38
24. Secondary/Service Conduit Installation from Padmount Transformer .....	39
25. Storm Water Diversion for Padmount Equipment .....	40
26. 15KV Primary Cable Conduit Sizing Chart .....	41

**TABLE OF CONTENTS**

	<u>PAGE</u>
J. EXHIBITS	
27. 600V Multi-plex Cable Conduit Sizing Chart .....	42
28. 600V THHN-AL Cable Conduit Sizing Chart .....	43
29. 600V THHN-CU Cable Conduit Sizing Chart .....	44
30. 3-Phase Transformer Pad Dimensions (45-1000 KVA) .....	45
31. 3-Phase Transformer Pad Dimensions (1500-2500 KVA) .....	46
32. 3-Phase Secondary Cabinet Pad Dimensions (Small Cabinet) .....	47
33. 3-Phase Secondary Cabinet Pad Dimensions (Large Cabinet) .....	48
34. 3-Phase Secondary Cabinet Dimensions (Small Cabinet) .....	49
35. 3-Phase Secondary Cabinet Dimensions (Large Cabinet) .....	50
36. 3-Phase Transformer & Cabinet Trough (Front to Back) .....	51
37. 3-Phase Transformer & Cabinet Trough (Side to Side) .....	52

## TERMS AND DEFINITIONS

<b>Conduit System:</b>	Any combination of duct, conduits, cabinets, and vaults joined to form an integrated whole.
<b>Conduit Stub-up:</b>	Any vertical length of conduit that allows above ground access to an underground electrical conduit raceway.
<b>Developer:</b>	Architect, engineer, electrician, owner, or contractor responsible for the installation of the electric facilities.
<b>Utility Easement:</b>	A legal document giving the Utility limited use of private property to provide electric service.
<b>Conduit Ells:</b>	Heavy wall rigid Schedule 40 PVC conduit elbow; gray in color; Electrical Grade, radius according to size: 1" diameter PVC = 18" radius elbow minimum 2", 3", 4" diameter PVC = 24" radius elbow minimum 6" diameter PVC = 36" radius elbow minimum 8" diameter PVC = 48" radius elbow minimum
<b>Final Grade:</b>	The grade at the time of completion of the site including all buildings.
<b>Overhead Construction:</b>	The standard placement of electric distribution lines on wood, metal, fiberglass composite, or concrete poles above ground.
<b>Point of Service:</b>	The point within a parcel of property that is determined the closest and most reasonable for Ocala Electric Utility to provide electric service. This is typically where OEU facilities end, and the customer's facilities begin.
<b>Primary Cable:</b>	Electrical cable used for the purpose of transmitting high voltage (more than one thousand volts) from one point to another.
<b>Primary Riser:</b>	Any vertical length of conduit used to transition overhead primary to underground primary.
<b>Primary Cabinet:</b>	An above ground metal enclosure, used by the utility for joining primary electrical cables.
<b>Primary Conduit:</b>	Conduit intended for use with primary cable. Must be 3" diameter or larger.
<b>Raceway:</b>	An enclosed channel designed expressly for holding wire or cables. A conduit is a raceway, so is a duct.
<b>Right-of-way:</b>	A strip of land occupied or intended to be occupied by a road, crosswalk, railroad, electric power line, oil or gas pipeline, water main, sanitary or storm sewer main, or for similar use.
<b>Riser Stub-up:</b>	A vertical length of conduit installed above ell at pole or stub-up location.

<b>Secondary Cabinet:</b>	Junction point to terminate secondary conductor. Above ground cabinet usually contains Utility cable and customer cable within the same enclosure.
<b>Secondary Cable:</b>	Electrical cable used for the purpose of transmitting low voltage (less than one thousand volts) from one point to another.
<b>Secondary Riser:</b>	Any vertical length of conduit used to transition overhead secondary to underground secondary.
<b>Secondary Vault:</b>	A below ground fiberglass enclosure, used for joining secondary electrical cables.
<b>Secondary Pedestal:</b>	An above-ground fiberglass enclosure, used for joining secondary electrical cables.
<b>Service Wire:</b>	Cable between OEU Electric facilities and meter pedestals or meters.
<b>Secondary/Service Conduit:</b>	Conduit intended for use with secondary or service cable. Raceway between OEU facilities and the customer's meter.
<b>Sweep:</b>	A gradual curve of the conduit raceway used to change direction of the conduit run.
<b>Transformer:</b>	Electrical device used for converting voltage levels.
<b>Transformer Pad:</b>	A ground mounted platform used to support a transformer.
<b>Underground Construction:</b>	The placement of electric primary and/or secondary cable and conduit below final grade.
<b>Warning Tape:</b>	Six (6) inch wide red warning tape installed in all trenches above conduit system at twelve (12) inches below final grade.

## DEVELOPER'S RESPONSIBILITIES

1. Installation of the underground electric conduit system shall not begin until the contractor is issued prints stamped “**APPROVED FOR CONSTRUCTION**” and initialed by the OEU Engineer or Technician assigned to the project. Any print(s) that are unstamped or stamped “preliminary” cannot be used for construction. Field changes to the conduit design must be approved by OEU in writing.
2. Construction site must be within six (6) inches of final grade, or the Developer must provide elevations for the conduit route before any conduit installation may begin.
3. The conduit system must be inspected by an authorized OEU inspector, Electric Engineering Division, (352) 351-6620 prior to closing the trench. Failure to comply will result in re-opening of the trench at the Developer’s expense.
4. The Developer will be responsible for staking all electrical cable routes, cabinets, vaults, and transformer locations as indicated in the approved construction drawings supplied by OEU. Any relocation needed after the conduit is installed will be at the Developer’s expense.
5. The Developer shall be responsible for supplying property markers, right-of-way markers, radius of curvature markers, sidewalk markers, and curb markers as needed for the electrical conduit installation before, during and after construction.
6. The Developer shall be held responsible and liable for the electrical conduit system until OEU Electric Engineering Division accepts it. The conduit installed will be officially accepted when OEU successfully installs cable in the conduit system. All as-built drawings must be submitted to the Electric Engineering Division prior to final acceptance.
7. The Developer shall be responsible to ensure that shrubs, plants, and structures are kept nine (9) feet from the front side of pad-mount transformers, and three (3) feet from the other sides. OEU reserves the right to remove any obstructions without notice to the owner if any deviations from this standard are encountered in the field. (SEE EXHIBIT 13).
8. City, County or State Road Permits and Railroad Permits will be obtained by OEU as necessary. No construction can be started until all applicable approved permits are received.
9. If a temporary construction service is required, the meter post will be installed at the right-side rear of the transformer or the rear of the secondary vault. (SEE EXHIBIT 18).
10. For Commercial installations, the Developer shall provide service conduit and conductor from the meter can to the secondary cabinet or padmount transformer.

**These specifications reflect minimum requirements and OEU reserves the right to alter or impose more stringent requirements as necessary for good engineering design.**

## TRENCH SPECIFICATIONS AND PROCEDURES

1. All primary and secondary conduits shall utilize the same trench whenever possible.
2. **Depth:** All trenches must be level and dug to allow thirty-six (36) inches of fill from the top of the conduit to final grade.
3. **Width:** All trenches must be a minimum of six (6) inches in width. If more than one conduit is being installed in a trench, no stacking of conduits is permitted. All conduits must lay flat in the trench. (SEE EXHIBIT 19).
4. After the Electric Engineering Division has inspected and approved the conduit within an opened trench, the trench must then be backfilled with soil free from any debris. This backfill soil must be on site and inspected prior to use for backfilling.
5. The Developer shall be responsible for the disposal of any foreign materials that are removed from any trench.
6. The Developer shall be responsible for all compaction (if needed) within the road right-of-way and on private property. This includes all landscaping and swale reconstruction.
7. Whenever applicable, trenching and backfilling (including compaction) will conform to City, County, or State jurisdictions. Where trench crosses present or future pavement or roadways, compaction and density testing may be required to conform to article 125-8.3 of the Florida Department of Transportation Specifications for Road and Bridge Construction.
8. The Developer shall supply and install underground warning tape directly above the conduit in all trenches and at a depth of twelve (12) inches below final grade. (SEE EXHIBIT 10).



## **REQUIREMENTS FOR JOINT USE OF TRENCH**

For other utilities wanting to utilize the same trench with OEU, the following guidelines and requirements must be followed:

1. Utilities that are providing services with fiber optic cable, telephone cable, or coaxial TV cable are permitted to utilize an electric trench. When any of these utilities are required to occupy the same trench, each utility must maintain a minimum vertical clearance of twelve (12) inches and a minimum horizontal clearance of eighteen (18) inches separation from the electrical conduit. (SEE EXHIBIT 11).
2. Utilities that are providing services with water pipes, sewage pipes, or natural gas pipes & lines are preferred to have their own separate trench whenever possible. If these utilities are situated parallel to an electrical conduit in the same trench or a nearby trench, each utility must maintain a minimum horizontal clearance of sixty (60) inches separation from the electrical conduit. If any of these utilities have a perpendicular crossing over or under an electrical conduit, a minimum vertical clearance of twelve (12) inches separation must be maintained. (SEE EXHIBIT 12).

## CONDUIT SPECIFICATIONS

1. Size and type of conduit and ells will be specified on construction print(s).
2. When not in a loop system, all primary conduit runs for Commercial Applications shall include a spare conduit for the length of the radial, including stub-ups.
3. When not in a loop system, all primary and secondary conduit runs for Residential Applications shall include a spare conduit for the length that is inaccessible. (For example: lengthwise under driveways; or under other objects that would not allow normal trenching or digging to replace conduit in the future).
4. **All conduits** shall be schedule 80 rigid PVC, schedule 40 rigid PVC, or SDR-13.5 conduit electrical grade; NEMA TC-2 specification; UL approved; rated for 90 degree C cable; furnished with coupling or integral long bell; gray in color; underground applications.
5. **Conduit couplings** shall be “long line” type and preferred with a center stop to ensure the proper depth of connection is made between adjoining pieces of conduit.
6. **Primary/Secondary/Service/Lighting Risers** shall be schedule 80 PVC conduit and are the responsibility of OEU.
7. **Primary/Secondary/Service/Lighting Riser Pole Stub-ups** shall be schedule 40 PVC conduit.
8. **Primary/Secondary/Service/Lighting Equipment Stub-ups** shall be schedule 40 PVC conduit.
9. **Primary/Secondary/Service Ells** shall be 90-degree elbows, schedule 40 PVC, with the following minimum dimensions: 2”, 3”, & 4” PVC = 24” radius; 6” PVC = 36” radius; 8” PVC = 48” radius.
10. **Lighting Equipment Ells** shall be 90-degree elbows, schedule 40 PVC, with the following minimum dimensions: 1” PVC = 18” radius; 2” & 3” PVC = 24” radius.
11. **C.T. Metering Ells** shall be 90-degree elbows, schedule 40 PVC, 1” PVC = 18” radius minimum.
12. **C.T. Metering Conduit raceways** shall be 1” schedule 40 PVC conduit. Maximum length from the transformer pad to metering equipment to be twenty-five (25) feet.
13. **Primary/Secondary/Service/Lighting Conduit raceways** shall be schedule 40 PVC or SDR-13.5 electrical grade conduit. If SDR-13.5 conduit is used, the two ends of each separate conduit run must be schedule 40 PVC for the last ten (10) feet and adjoined to approved schedule 40 PVC elbows. Bending or flexing the SDR-13.5 conduit into a 90-degree elbow shape is not permissible. (SEE EXHIBIT 20).

## CONDUIT PROCEDURES

### **Raceways:**

1. Primary conduit runs shall not have more than three (3) bends within each run regardless of whether the bend is constructed from a 90-degree or 45-degree ell. This includes the ells for stub-ups.
2. Field bending of conduit, by heating, is not permitted.
3. Any conduit that passes under pavement must be encased in concrete with a minimum of six (6) inches of concrete on top and bottom, and three (3) inches on both sides. Installation of concrete is not a normal construction practice. Conduit supports must be installed every five (5) feet and the conduit must be secured in a manner that will prevent the conduit from floating during the installation of the concrete. (SEE EXHIBIT 2).
4. Conduit shall be installed in straight lines and be consistently level. Sweeps shall not be used unless specified on the construction print. If more than one conduit is being installed, the placement of conduits must be installed in a horizontal, side by side configuration. (SEE EXHIBIT 19).
5. **Depth of Conduit:** Primary and secondary conduit - minimum thirty-six (36) inches (to the top of the conduit) below final grade. (SEE EXHIBITS 4-7).
6. A continuous length of polypropylene 200-pound pull line shall be installed in each conduit with an excess of ten (10) feet secured at each end. (Spare riser conduits shall have thirty (30) feet of excess length of nylon pull string for future use). The cord shall be installed after the conduit is glued together and all joints are cured to prevent the cord from sticking to the conduit. (SEE EXHIBIT 8).
7. Open ends of all conduits shall be covered or sealed with duct tape applied at double thickness. The tape shall cover the entire opening and all exposed string to prevent entry of water and other foreign materials. This also includes unfinished conduit runs left in a trench at the end of each workday. (SEE EXHIBIT 8).
8. All conduit runs shall be marked at the top of the stub-up with the same identification number as the first up-line or down-line electrical device to identify ends of conduit runs. Marks shall be made with a permanent marking pen, black in color. Identification numbers are indicated on the construction print with an alphanumeric character (for example: F1123). Any questions should be referred to the OEU representative responsible for the project.
9. PVC cleaner and cement shall be applied to all conduit joints in accordance with the manufacturer's specifications.
10. The raceway(s) are to be clear of any obstructions. The utility will pull a steel mandrel through the raceway(s) to verify proper installation. The contractor must correct any obstructions encountered.

**Riser Stub-ups:**

1. Riser stub-ups at OEU poles shall consist of a ninety (90) degree schedule 40 PVC ell at the bottom of the trench with a schedule 40 stub-up that is to extend a minimum of two (2) feet above final grade. Contractor shall supply and install these stub-ups on the side of the pole opposite of oncoming traffic, often referenced as the field side. (SEE EXHIBIT 1).
2. Primary, secondary, and service riser pole conduits shall be installed by OEU and adjoined to the conduit stub-ups installed by the contractor.

**Transformer Locations:**

1. All conduits shall be stubbed up and capped at a minimum of four (4) feet above final grade at all transformer locations. All stub-ups shall be schedule 40 PVC.
2. There shall be a four (4) inch minimum and seven (7) inch maximum separation between the primary and secondary conduit for single-phase transformer locations. (SEE EXHIBIT 4).
3. There shall be an eight (8) inch minimum separation between the primary and secondary conduits for all three-phase transformer locations, unless otherwise specified on transformer pad drawing. (SEE EXHIBIT 5).
4. OEU is responsible for supplying concrete pads for all single-phase transformers.
5. The Developer is responsible for supplying concrete pads for all three-phase transformers and/or three-phase secondary cabinets. The Developer can either purchase pre-manufactured concrete pads for this equipment, or they can build their own concrete pads. All equipment pads built by the Developer must have the pad forms inspected by OEU prior to pouring concrete. Dimensions of equipment pads are site-specific and must be approved by OEU prior to construction. All equipment pads must use #3 reinforcing rods to be installed twelve (12) inches on center, and the concrete must be cured to 3000 PSI at twenty-eight (28) days. Concrete pad thickness must be seven (7) inches. (SEE EXHIBITS 30-37).

**Primary Cabinet Locations:**

1. Conduit stub-ups at all single-phase primary cabinet locations shall be grouped together with one (1) inch of separation between each conduit. The conduit shall be stubbed up and capped at a minimum of four (4) feet above final grade. Conduit configuration shall conform to the ground sleeve opening (12" x 24"). All stub-up conduits shall be schedule 40 PVC. (SEE EXHIBIT 6).
2. Conduit stub-ups at all two (2) and three (3) phase primary cabinet locations shall be grouped in phases. Same phase conduits shall have one (1) inch of separation between each conduit and six (6) inches shall separate the phases. The conduit shall be stubbed up and capped at a minimum of four (4) feet above final grade. Conduit configuration shall conform to the ground sleeve opening (12" x 54" for 200A or 17" x 71" for 600A). All stub-up conduits shall be schedule 40 PVC. (SEE EXHIBIT 7).

## SUMMARY

### **WORK TO BE PERFORMED AND MATERIAL TO BE FURNISHED BY THE DEVELOPER:**

1. Open and close all trenches as required by the work order.
2. Furnish and install all conduits as required by the work order.
3. Provide a pull line in each conduit run that will be utilized by OEU.
4. Supply and install warning tape above all conduit runs.
5. For 3-phase applications, construct concrete equipment pads per work order specifications.
6. For Commercial applications, install secondary/service cable from the transformer to all other equipment as required by the work order.

### **WORK TO BE PERFORMED AND MATERIAL TO BE FURNISHED BY THE OEU:**

1. Furnish and install distribution transformers.
2. Furnish and install all primary and secondary cabinets, vaults, or pedestals.
3. Furnish, and install primary (high voltage) conductors.
4. For Residential applications, install secondary/service cable from the transformer to all other equipment as required by the work order.
5. Provide all construction prints needed for the electrical conduit installation.
6. Perform regular inspections of the conduit system as it is being installed.
7. Furnish and install all conduits that adjoin to the Developer's riser pole stub-ups.

## Electric Work Order Symbol Legend

### Distribution Transformer

- ▲ Distribution Transformer





### Fuses

- S Overhead Expulsion
- Ⓢ Underground Expulsion



### Flying Tap

-  Flying Tap

### Switches

-  Manual Hook Stick Disconnect
-  Gang Operated ABGO Load Break
-  Single Phase Oil Switch
-  Underground Disconnect
-  Underground Load Break

### Capacitor Bank

-  Fixed Bank
-  Switched Bank

### Recloser

-  Recloser

### Sectionalizer

-  Sectionalizer

### Voltage Regulator Bank

-  Voltage Regulator Bank

### Surge Arrester

-  Surge Arrester

### Light

-  Light

### Span Guy

-  Span Guy

### Anchor Guy

- T Sidewalk
- Y Standard

### Overhead Primary Cable

- Single Phase (1 Dash)
- Two Phase (2 Dashes)
- Three Phase (3 Dashes)

### Underground Primary Cable

- ... Single Phase (1 Dot)
- ... Two Phase (2 Dots)
- ... Three Phase (3 Dots)

### Overhead Secondary Cable

- Overhead Secondary Cable

### Underground Secondary Cable

- Underground Secondary Cable

### Transmission Cable

- OH Transmission
- UG Transmission

### Poles

- Pole

### Riser

- ⊙ Riser

### Pad Structure

- Pad
- ▭ Transclosure

### Underground Vaults

- ⊙ SL Street Light Vault
- ⊙ SV Secondary Vault
- ⊙ V Primary Termination Vault
- ⊙ PB Primary Pullbox

### Pad Mounted Gear Cabinet

- ⊙ F Fuse Cabinet
- ⊙ S Switch Cabinet
- ⊙ V Termination Cabinet
- ⊙ SC Secondary Cabinet

### Work Location

- ⬡ Work Location

### Work Request Polygon

- None
- ▭ Initiated
- ▭ In Design
- ▭ In Construction
- ▭ Complete

### Conduit

- Transmission
- Primary
- Secondary
- Light
- Fiber

### Network Junctions

- ★ Network Junctions

### Electric Service Location

- All Other Meters
- ⊙ T Temp Pole Meter

### Open Point

- ⊙ OP OH Open Point (DDE)
- ⊙ OP UG Open Point

### Work Order Colors

- ▭ Existing Features
- ▭ Install Features
- ▭ Remove Features
- ▭ Leave Features
- ▭ Replace Features
- ▭ Transfer Install
- ▭ Transfer Remove

# OCALA ELECTRIC UTILITY STANDARDS

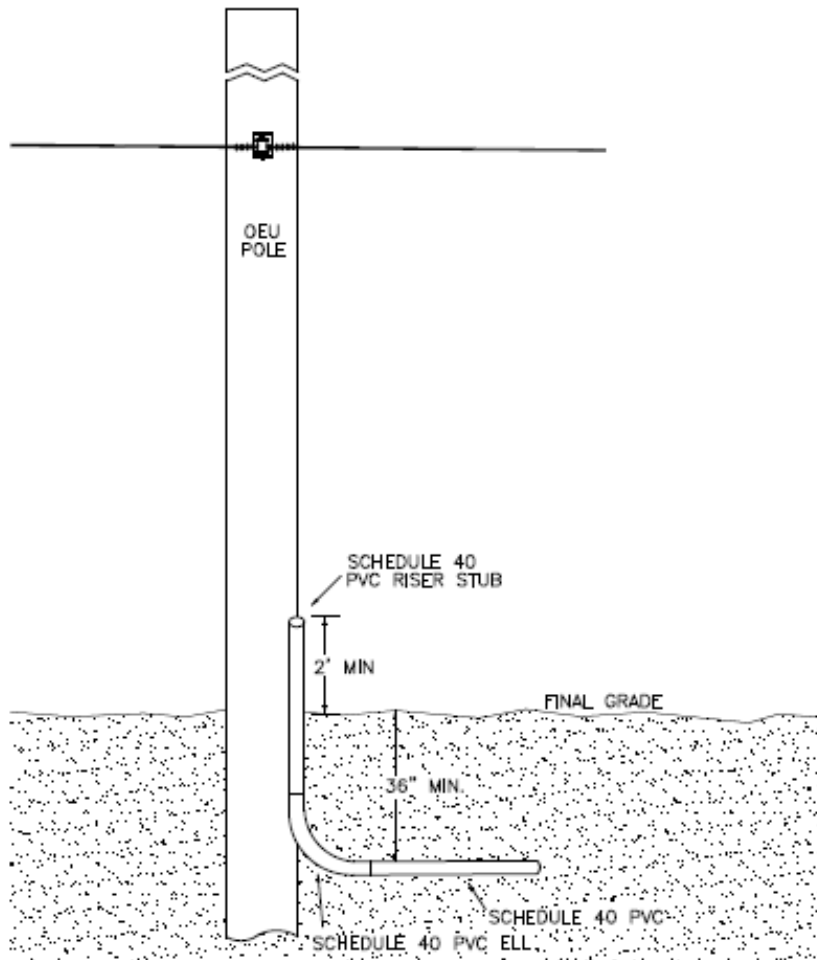

REVISED DATE: FEBRUARY 1, 2023

REVISED BY: FRANK BROWN

APPROVED BY: RANDY HAHN

## COMMERCIAL & RESIDENTIAL CONDUIT POLICY

### TYPICAL RISER POLE STUB-UP

#### EXHIBIT 1

# OCALA ELECTRIC UTILITY STANDARDS

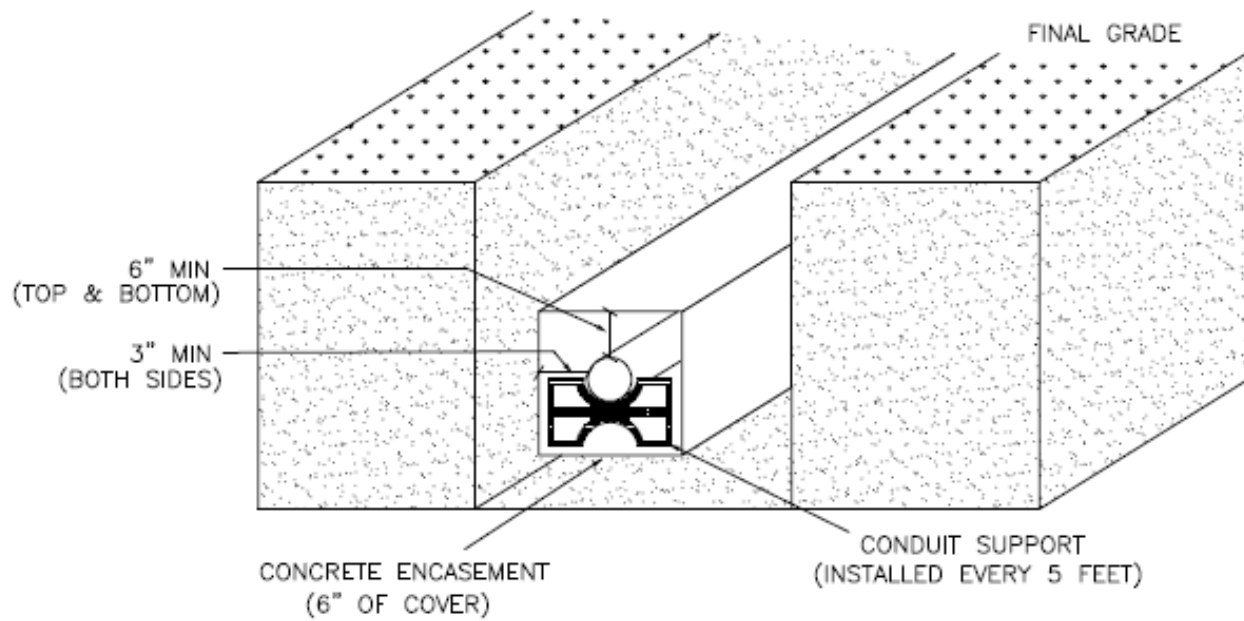

## NOTES

- 1.) CONDUIT DEPTH IS TYPICALLY 36" BELOW FINAL GRADE.
- 2.) CONDUIT MUST BE SECURED TO SUPPORTS TO PREVENT FLOATING.

REVISED DATE: FEBRUARY 1, 2025

REVISED BY: FRANK BROWN

APPROVED BY: RANDY HAHN

## COMMERCIAL & RESIDENTIAL CONDUIT POLICY

### CONCRETE ENCASEMENT AND SUPPORT PLACEMENT

#### EXHIBIT 2



OCALA ELECTRIC UTILITY STANDARDS

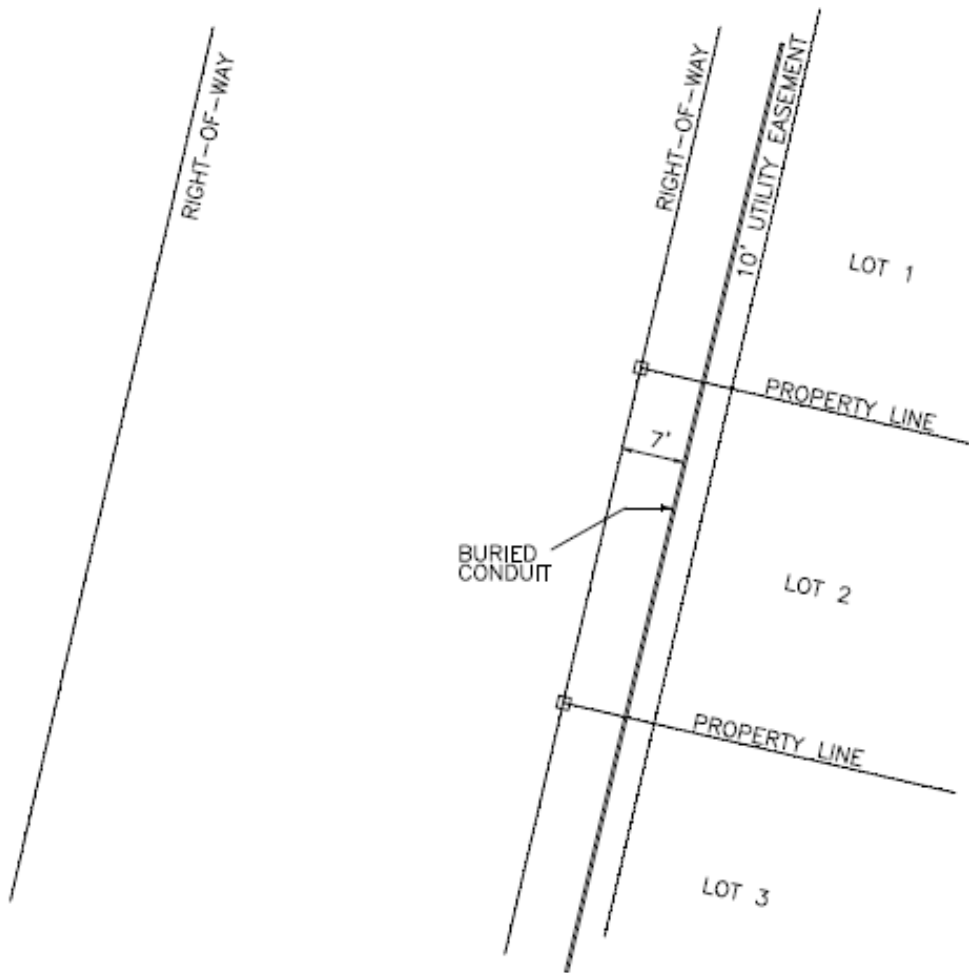
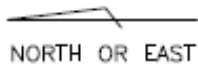

REVISED DATE: FEBRUARY 1, 2023

REVISED BY: FRANK BROWN

APPROVED BY: RANDY HAHN

COMMERCIAL & RESIDENTIAL CONDUIT POLICY

TYPICAL TRENCH LINE W/ RESPECT TO RIGHT-OF-WAY

EXHIBIT 3

# OCALA ELECTRIC UTILITY STANDARDS

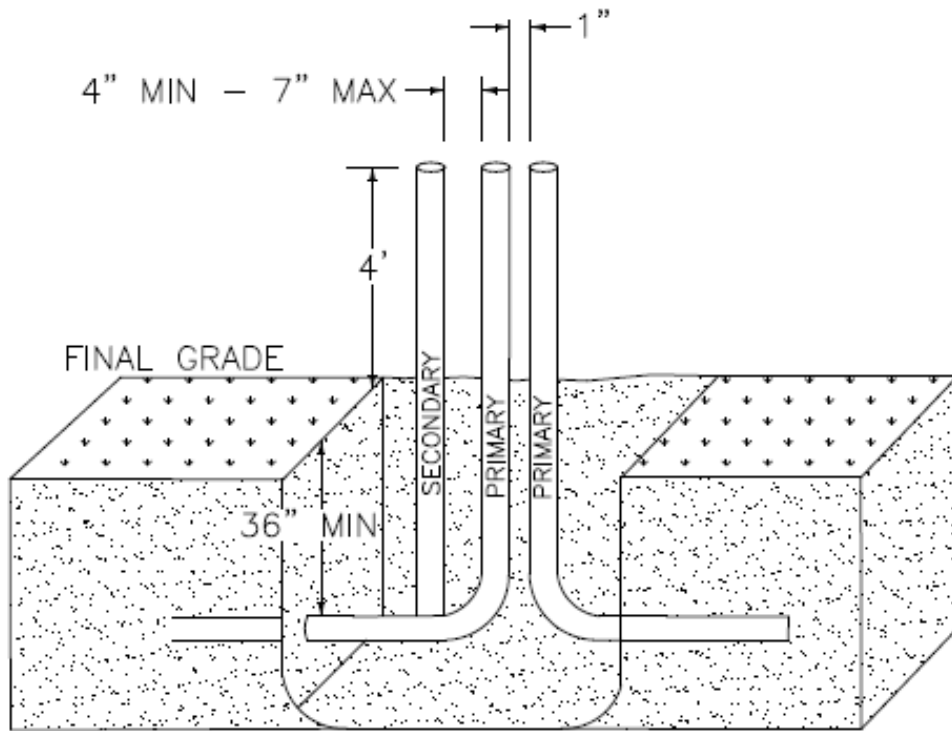
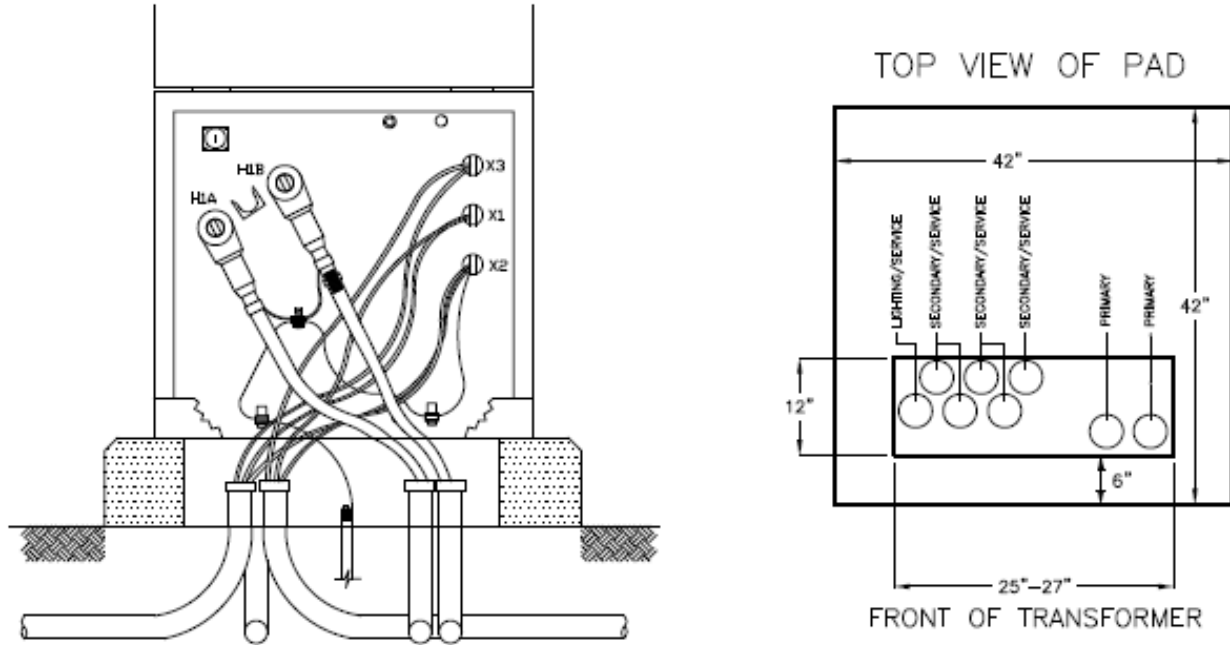

REVISED DATE: FEBRUARY 1, 2023

REVISED BY: FRANK BROWN

APPROVED BY: RANDY HAHN

## COMMERCIAL & RESIDENTIAL CONDUIT POLICY

### TYPICAL 1Ø TRANSFORMER LOCATION

#### EXHIBIT 4

OCALA ELECTRIC UTILITY STANDARDS

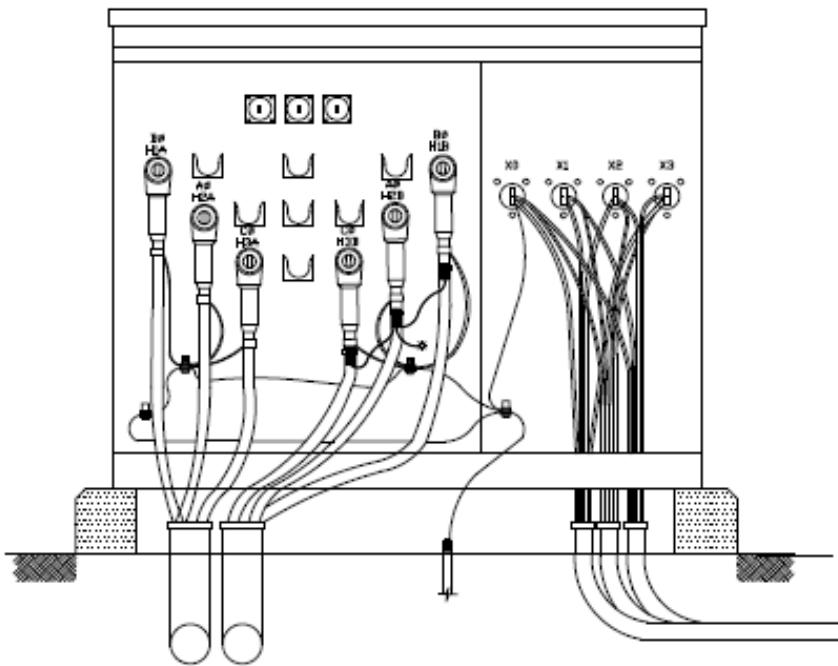

TOP VIEW OF PAD  
(DIMENSIONS MAY VARY)

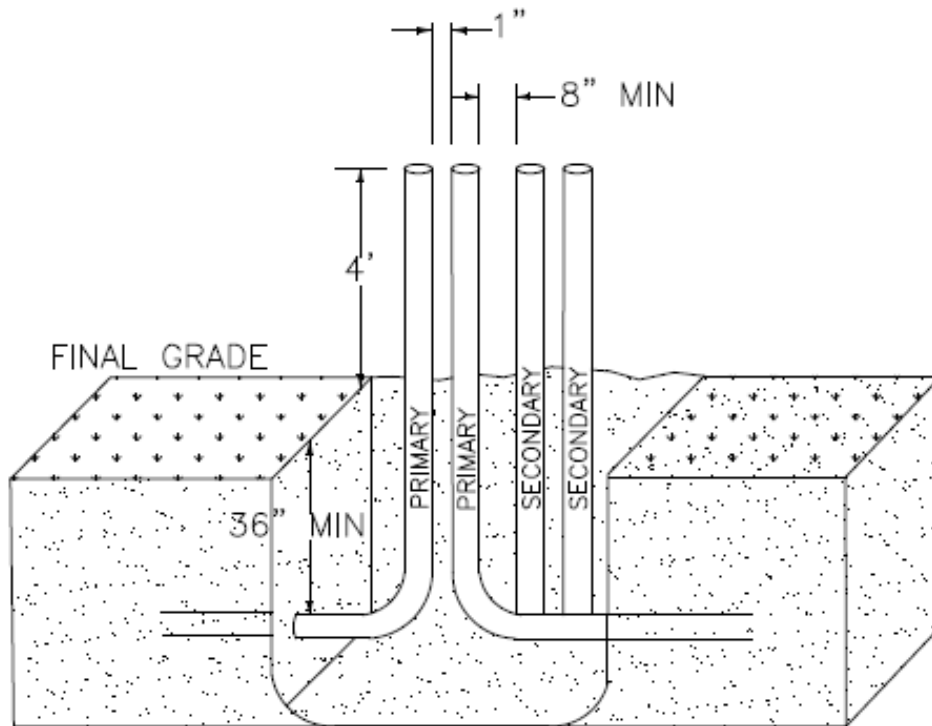
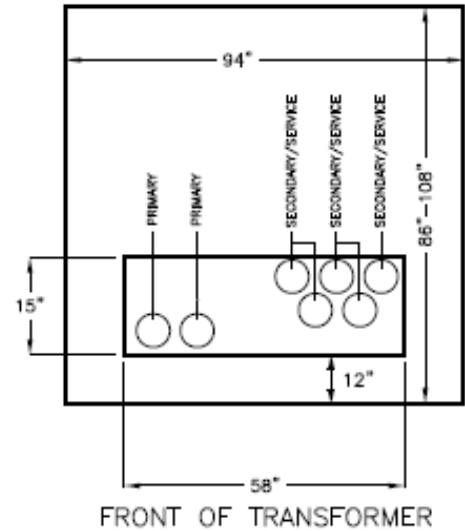

REVISED DATE: FEBRUARY 1, 2023

REVISED BY: FRANK BROWN

APPROVED BY: RANDY HAHN

COMMERCIAL & RESIDENTIAL CONDUIT POLICY

TYPICAL 3Ø TRANSFORMER LOCATION

EXHIBIT 5

# OCALA ELECTRIC UTILITY STANDARDS

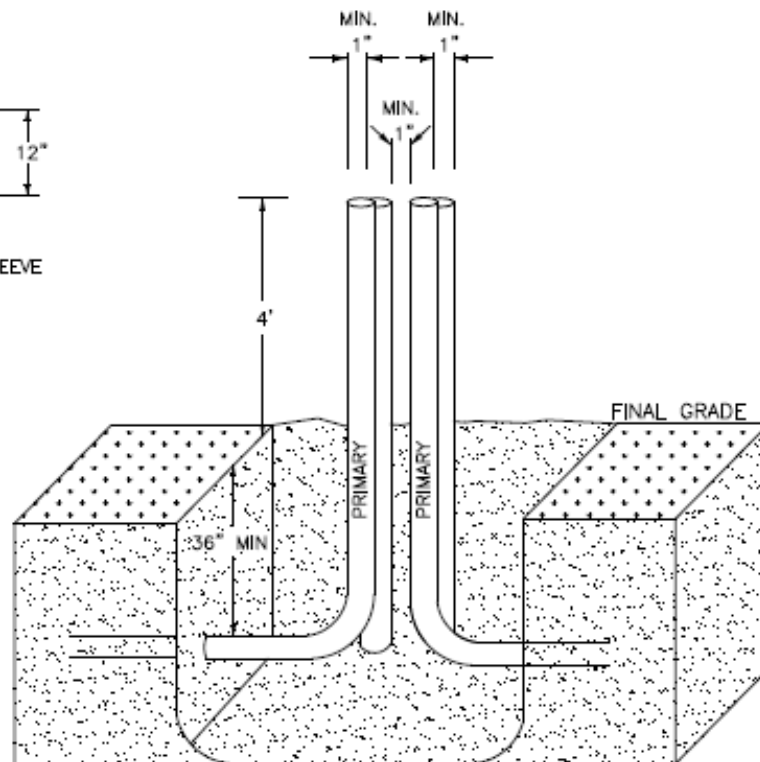
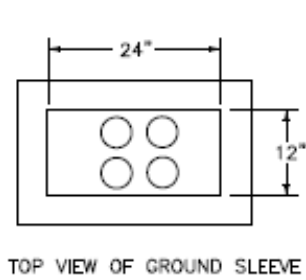
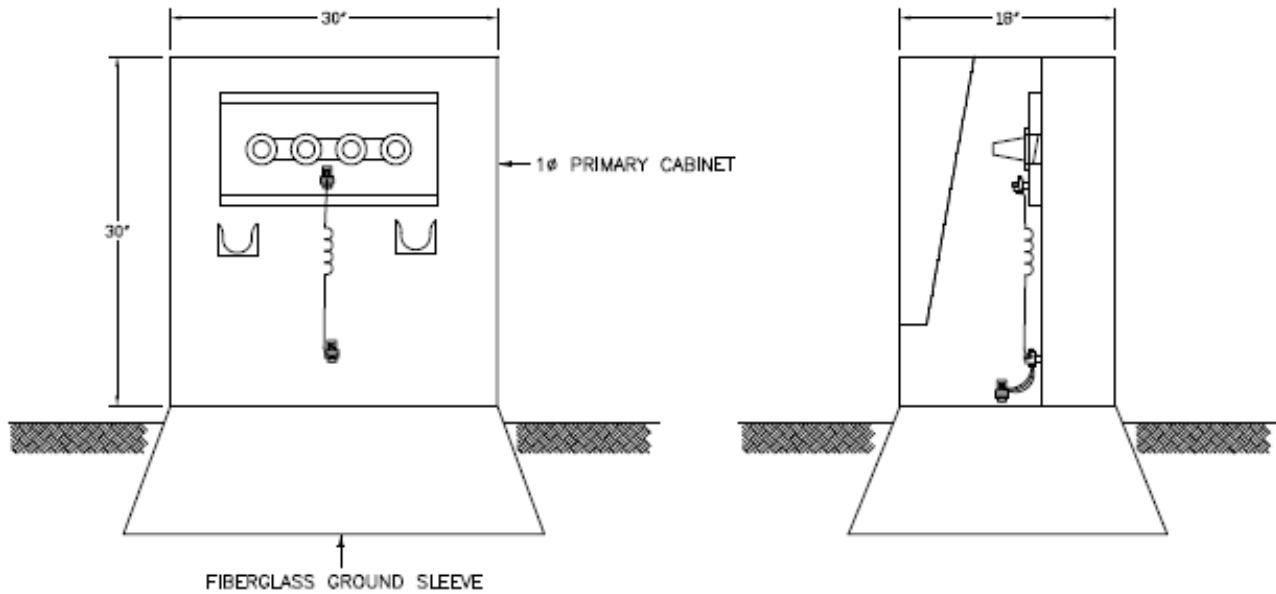

REVISED DATE: FEBRUARY 1, 2023

REVISED BY: FRANK BROWN

APPROVED BY: RANDY HAHN

## COMMERCIAL & RESIDENTIAL CONDUIT POLICY

### TYPICAL 1φ PRIMARY CABINET LOCATION

#### EXHIBIT 6

# OCALA ELECTRIC UTILITY STANDARDS

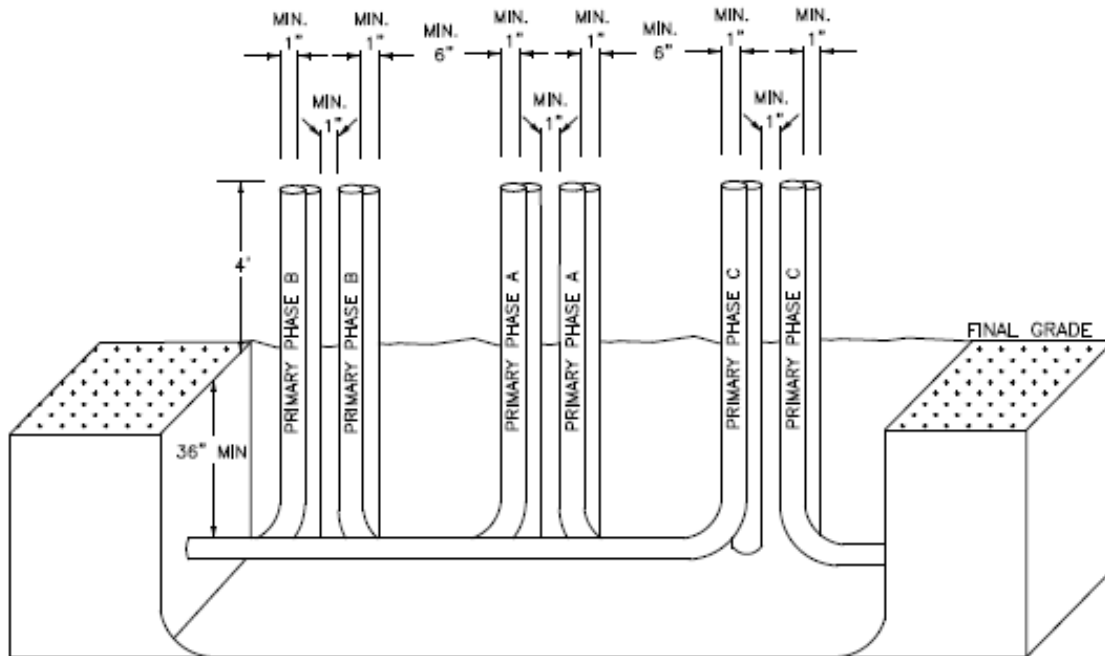
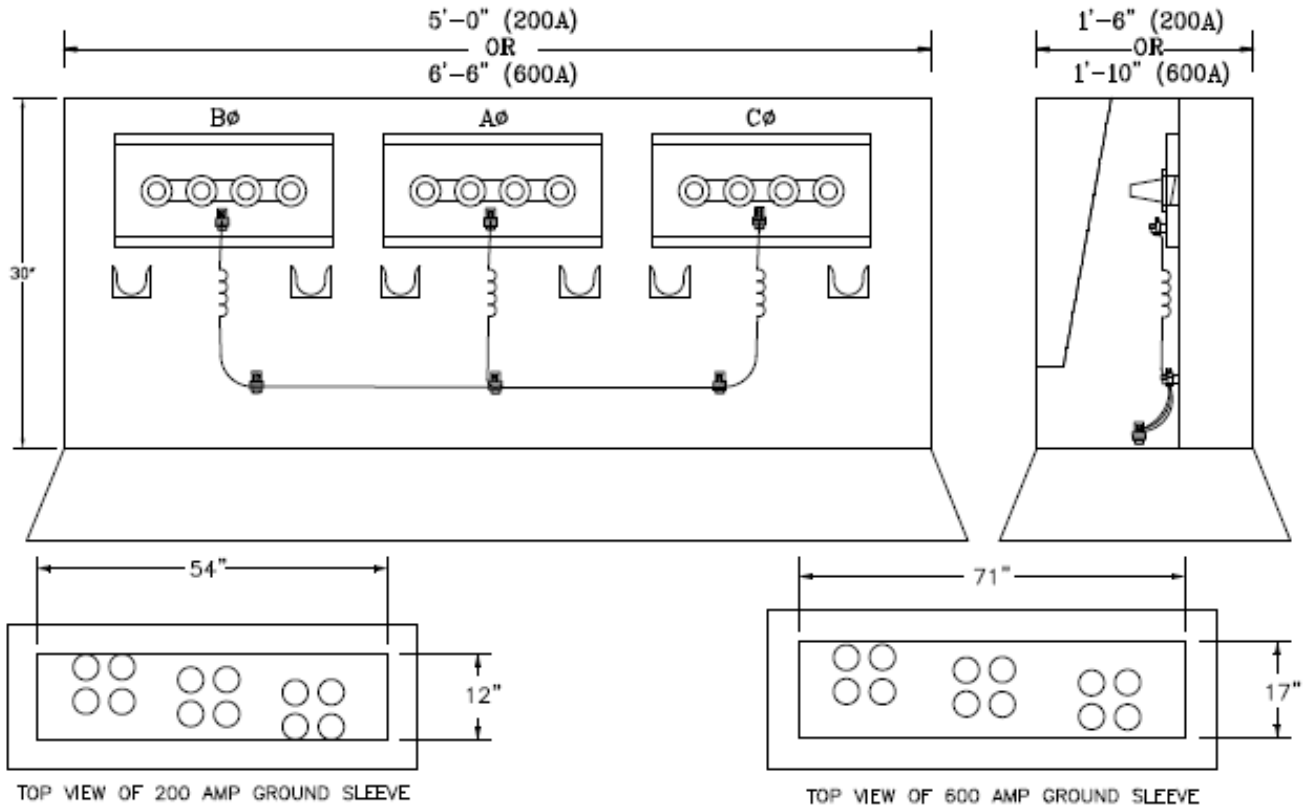

REVISED DATE: FEBRUARY 1, 2023

REVISED BY: FRANK BROWN

APPROVED BY: RANDY HAHN

## COMMERCIAL & RESIDENTIAL CONDUIT POLICY

### TYPICAL 3 $\phi$ PRIMARY CABINET LOCATION

#### EXHIBIT 7A

# OCALA ELECTRIC UTILITY STANDARDS

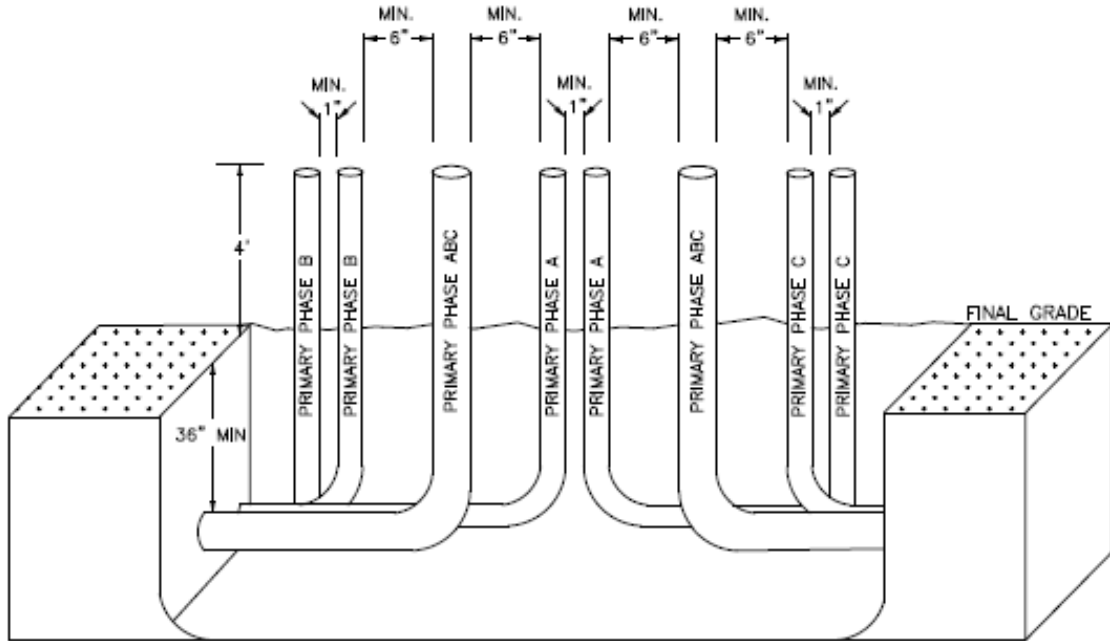
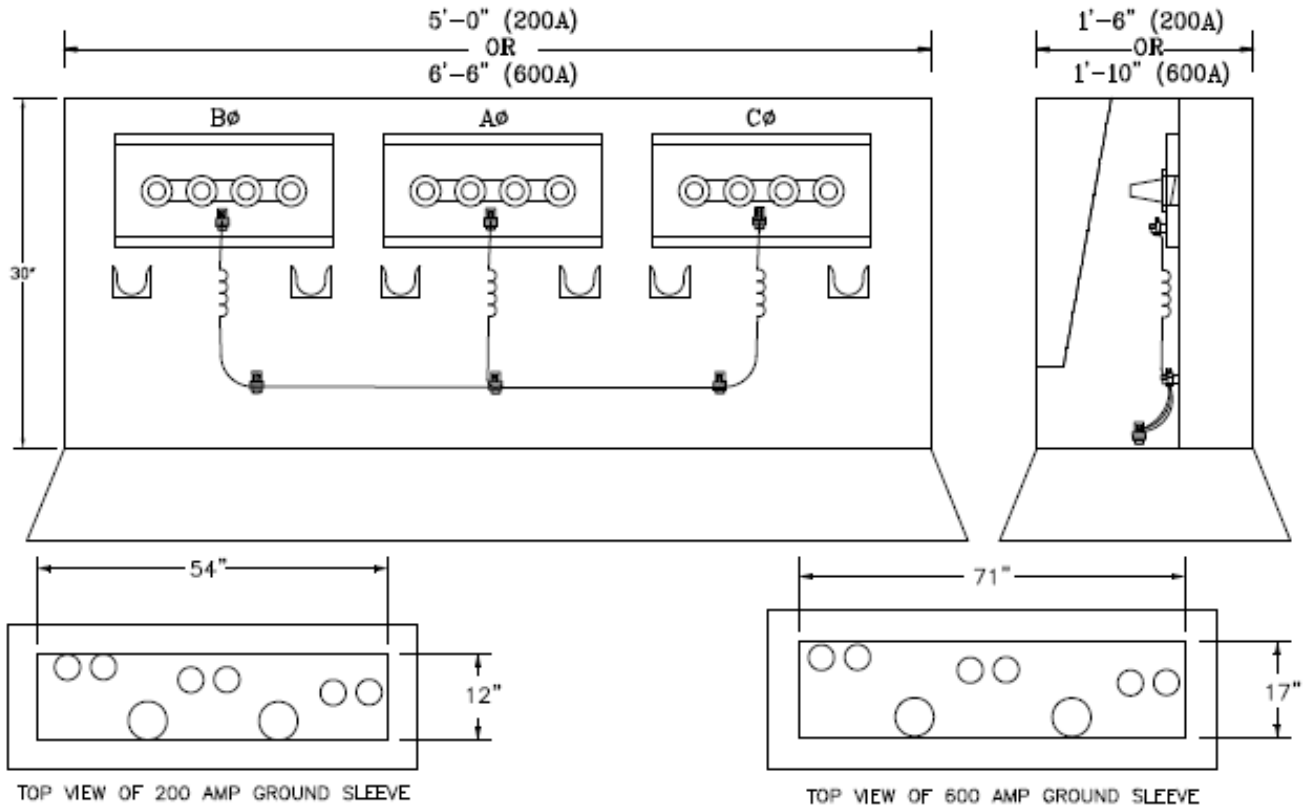

REVISED DATE: FEBRUARY 1, 2023

REVISED BY: FRANK BROWN

APPROVED BY: RANDY HAHN

## COMMERCIAL & RESIDENTIAL CONDUIT POLICY

### TYPICAL 3 $\phi$ PRIMARY CABINET LOCATION

#### EXHIBIT 7B

# OCALA ELECTRIC UTILITY STANDARDS

NOTE: DUCT TAPE SHALL BE APPLIED DOUBLE-THICKNESS OVER THE OPENING AND OVER THE EXPOSED PULL STRING.

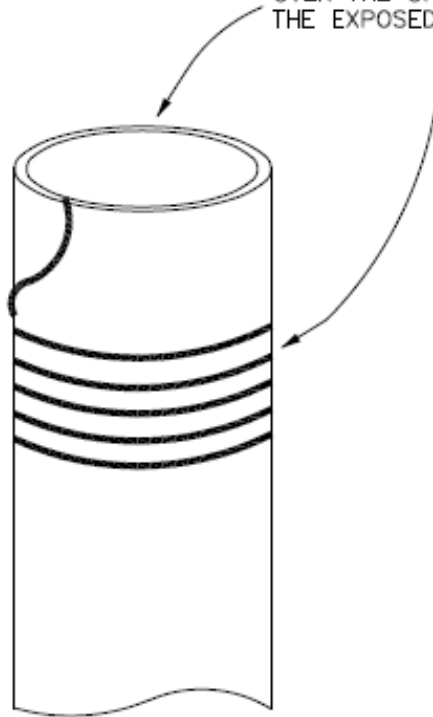

## PULL STRING REQUIREMENTS

- 1.) 200 LB. POLYPROPYLENE TWINE.
- 2.) 10'-0" EXCESS AT EACH END OF CONDUIT (MAIN STUB-UPS).
- 3.) 30'-0" EXCESS AT SPARE (FUTURE) RISER POLE STUB-UPS.

REVISED DATE: FEBRUARY 1, 2023

REVISED BY: FRANK BROWN

APPROVED BY: RANDY HAHN

**COMMERCIAL & RESIDENTIAL CONDUIT POLICY**

**CONDUIT STUB-UP END REQUIREMENTS**

**EXHIBIT 8**





OCALA ELECTRIC UTILITY STANDARDS

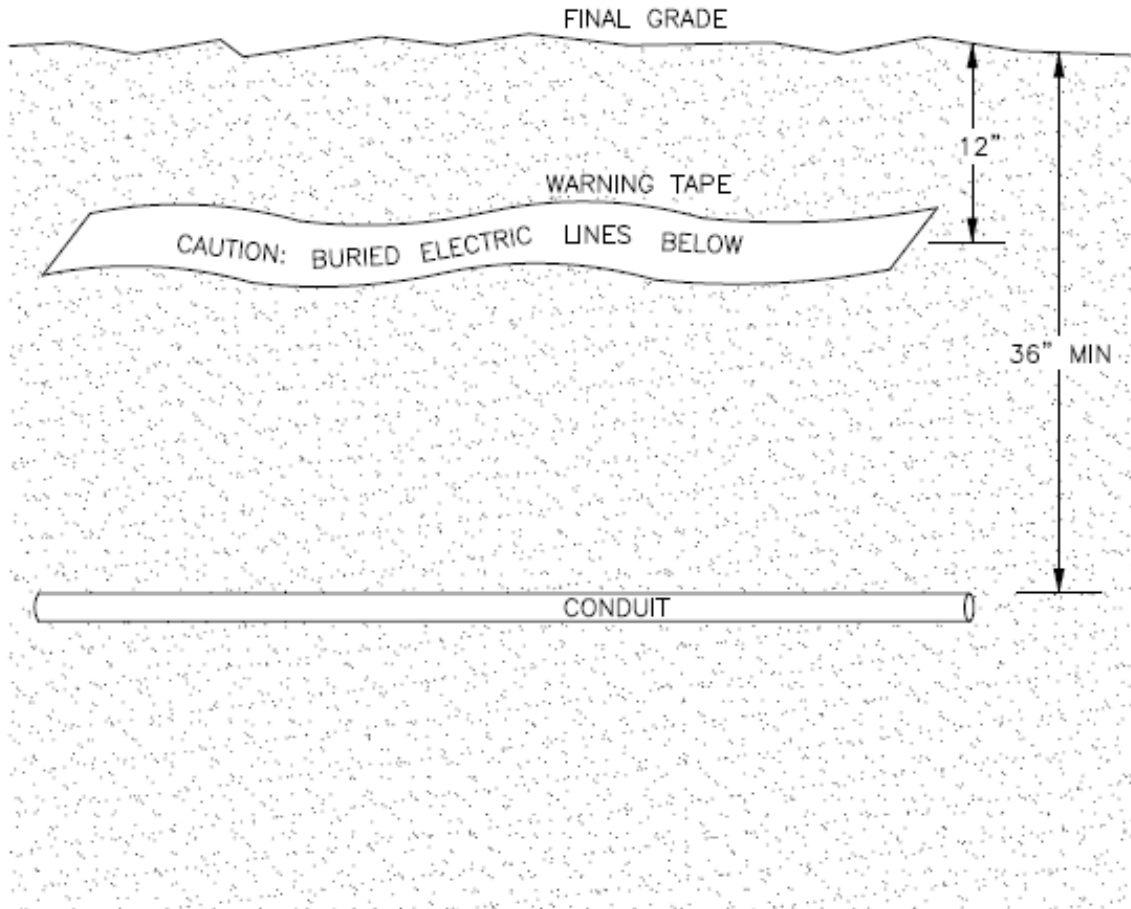

REVISED DATE: FEBRUARY 1, 2023

REVISED BY: FRANK BROWN

APPROVED BY: RANDY HAHN

**COMMERCIAL & RESIDENTIAL CONDUIT POLICY**

**WARNING TAPE PLACEMENT**

**EXHIBIT 10**

OCALA ELECTRIC UTILITY STANDARDS

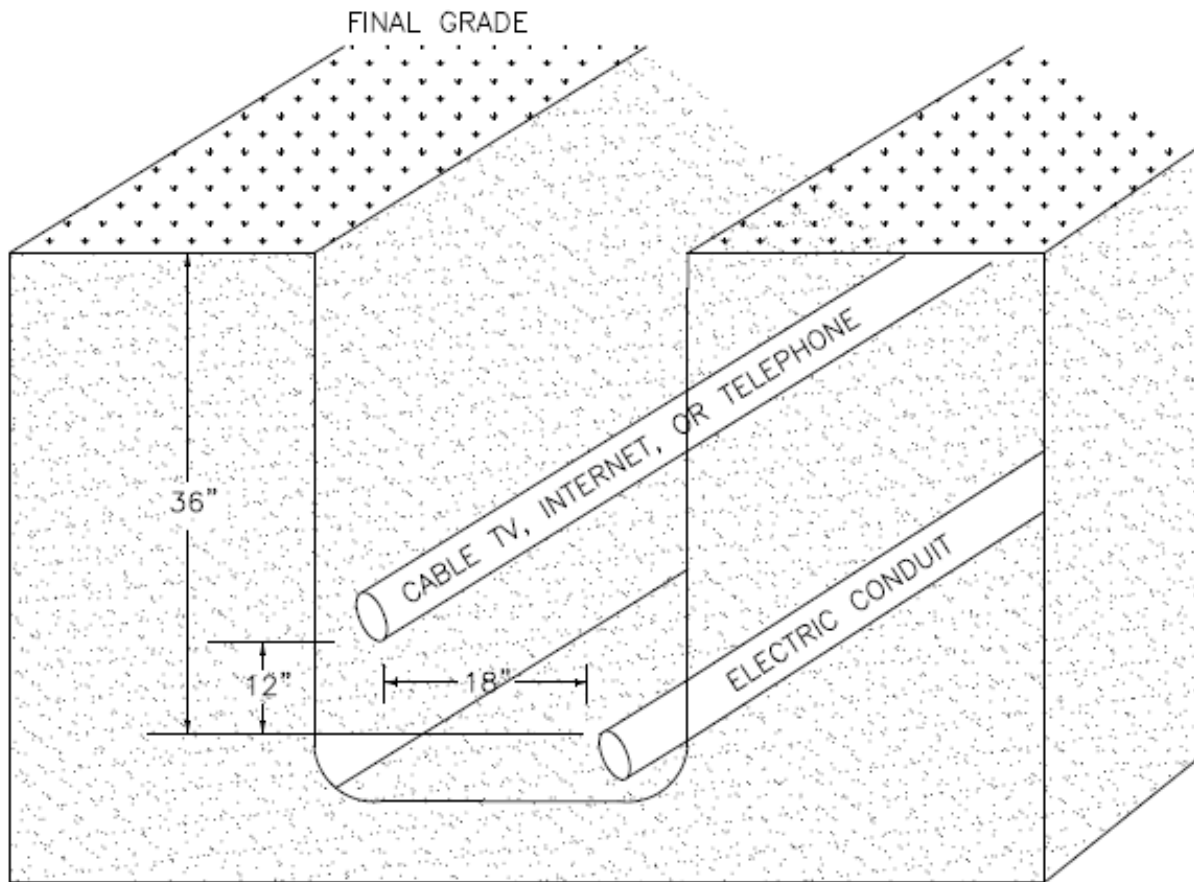

REVISED DATE: FEBRUARY 1, 2023

REVISED BY: FRANK BROWN

APPROVED BY: RANDY HAHN

COMMERCIAL & RESIDENTIAL CONDUIT POLICY

MINIMUM CLEARANCE (CABLE TV, INTERNET, TELEPHONE)

EXHIBIT 11

# OCALA ELECTRIC UTILITY STANDARDS

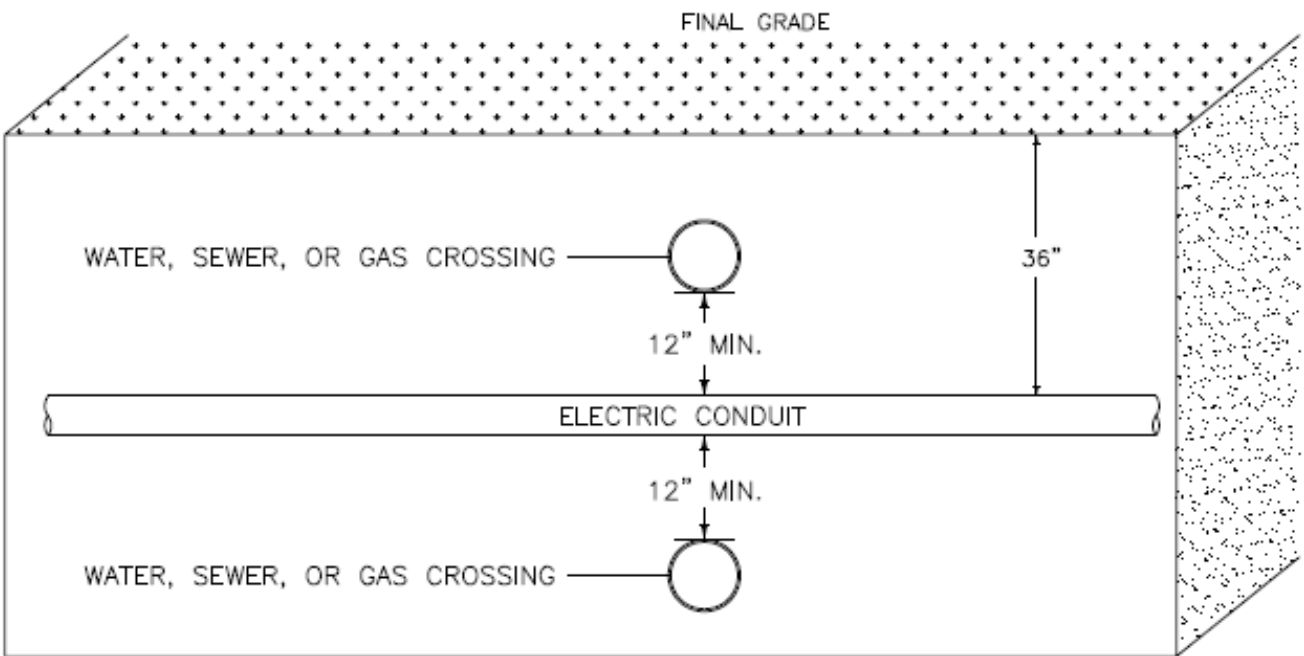
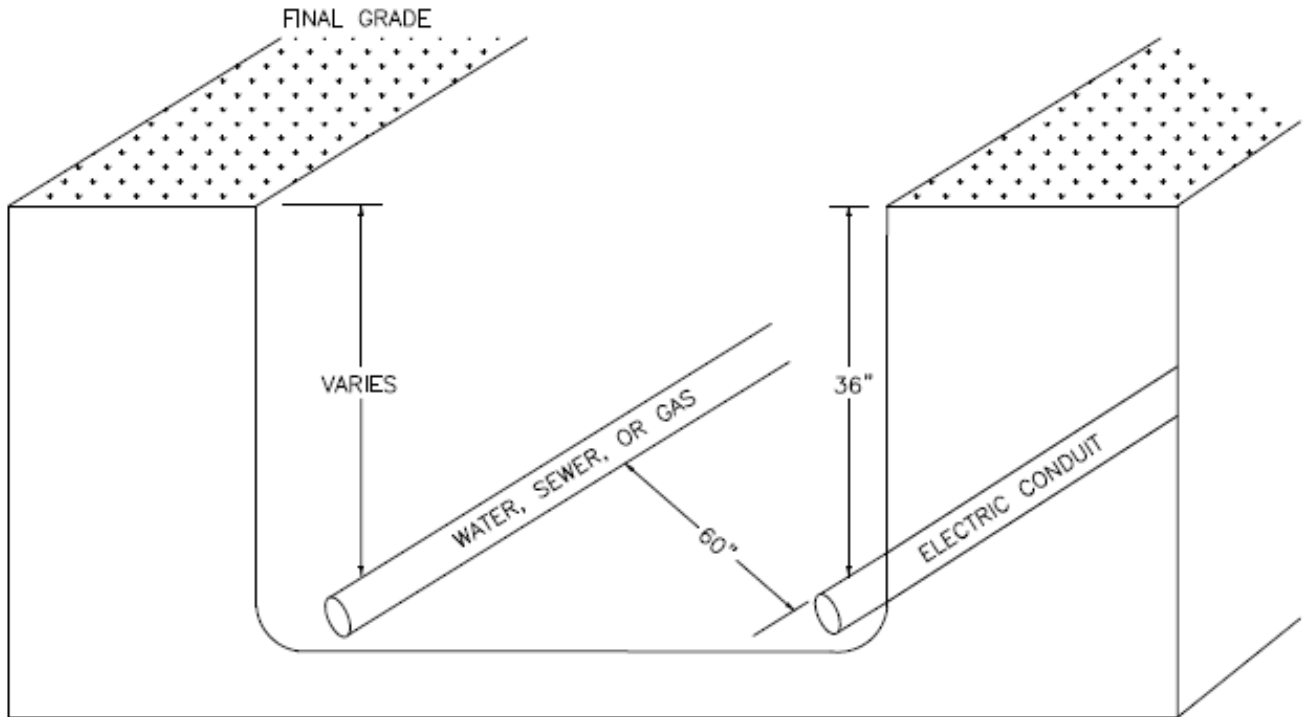

REVISED DATE: FEBRUARY 1, 2023

REVISED BY: FRANK BROWN

APPROVED BY: RANDY HAHN

## COMMERCIAL & RESIDENTIAL CONDUIT POLICY

### MINIMUM CLEARANCE (WATER, SEWER, GAS)

#### EXHIBIT 12

<p><b>⚠ WARNING</b></p>  <p><b>Hazardous voltage inside.</b> <b>Keep Out!</b> May shock, burn or cause death. If open or unlocked, immediately call <b>OCALA ELECTRIC UTILITY</b> <b>352-351-6666</b></p>	<p><b>Energized Electrical Equipment</b></p>  <p>We need room to work safely on this device. Please keep shrubs and structures 9 feet from the side with doors and 3 feet from other sides. Obstructions may be damaged or removed during service restoration or maintenance.</p>
 <p><b>Before Digging Call</b> <b>352-351-6650</b> <b>For Location of Underground Cable</b></p> <p><small>U6075W-OEU</small></p>	

REVISED DATE: FEBRUARY 1, 2025

REVISED BY: FRANK BROWN

APPROVED BY: RANDY HAHN

**COMMERCIAL & RESIDENTIAL CONDUIT POLICY**

**MINIMUM HORIZONTAL CLEARANCE AROUND EQUIPMENT**

**EXHIBIT 13**

# OCALA ELECTRIC UTILITY STANDARDS

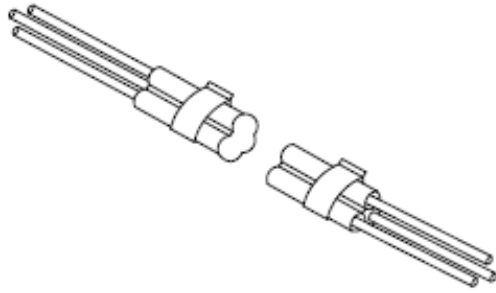

**NOTES:**

1. THIS ASSEMBLY INCLUDES A GELCAP-SL STUB CONNECTION KIT FOR STREET LIGHTS. REFER TO STOCK ITEM E07-04-0280 FOR DETAILS.

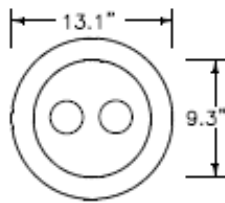
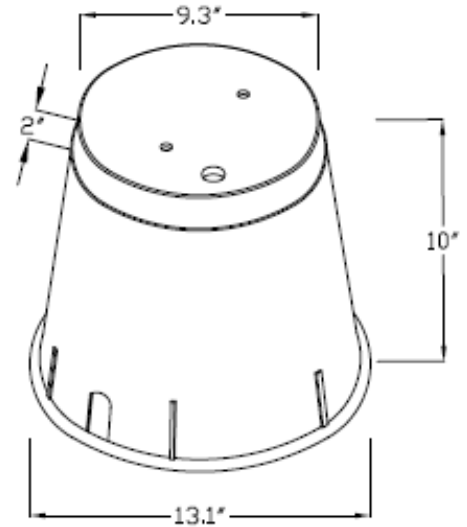

TOP VIEW OF VAULT

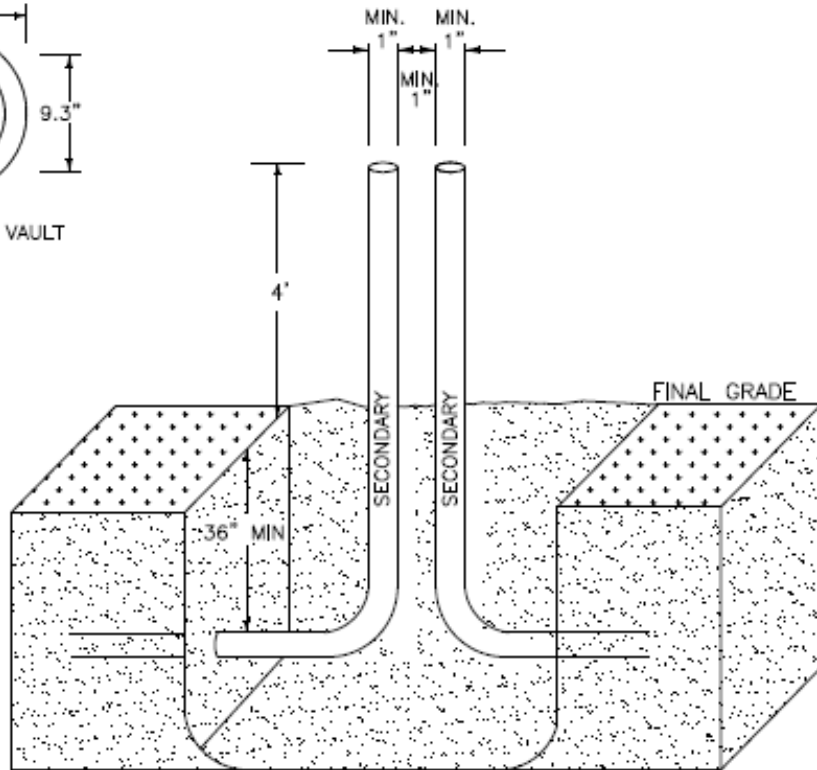

REVISED DATE: FEBRUARY 1, 2023

REVISED BY: FRANK BROWN

APPROVED BY: RANDY HAHN

## COMMERCIAL & RESIDENTIAL CONDUIT POLICY

### TYPICAL STREET LIGHT VAULT LOCATION

#### EXHIBIT 14

# OCALA ELECTRIC UTILITY STANDARDS

NOTE: PEDESTALS MUST HAVE 3" PVC CONDUIT STUB-OUTS INSTALLED PRIOR TO ENERGIZATION BY OEU PERSONNEL TO PREVENT DAMAGE TO EQUIPMENT AND TO PREVENT ACCIDENTAL CONTACT.

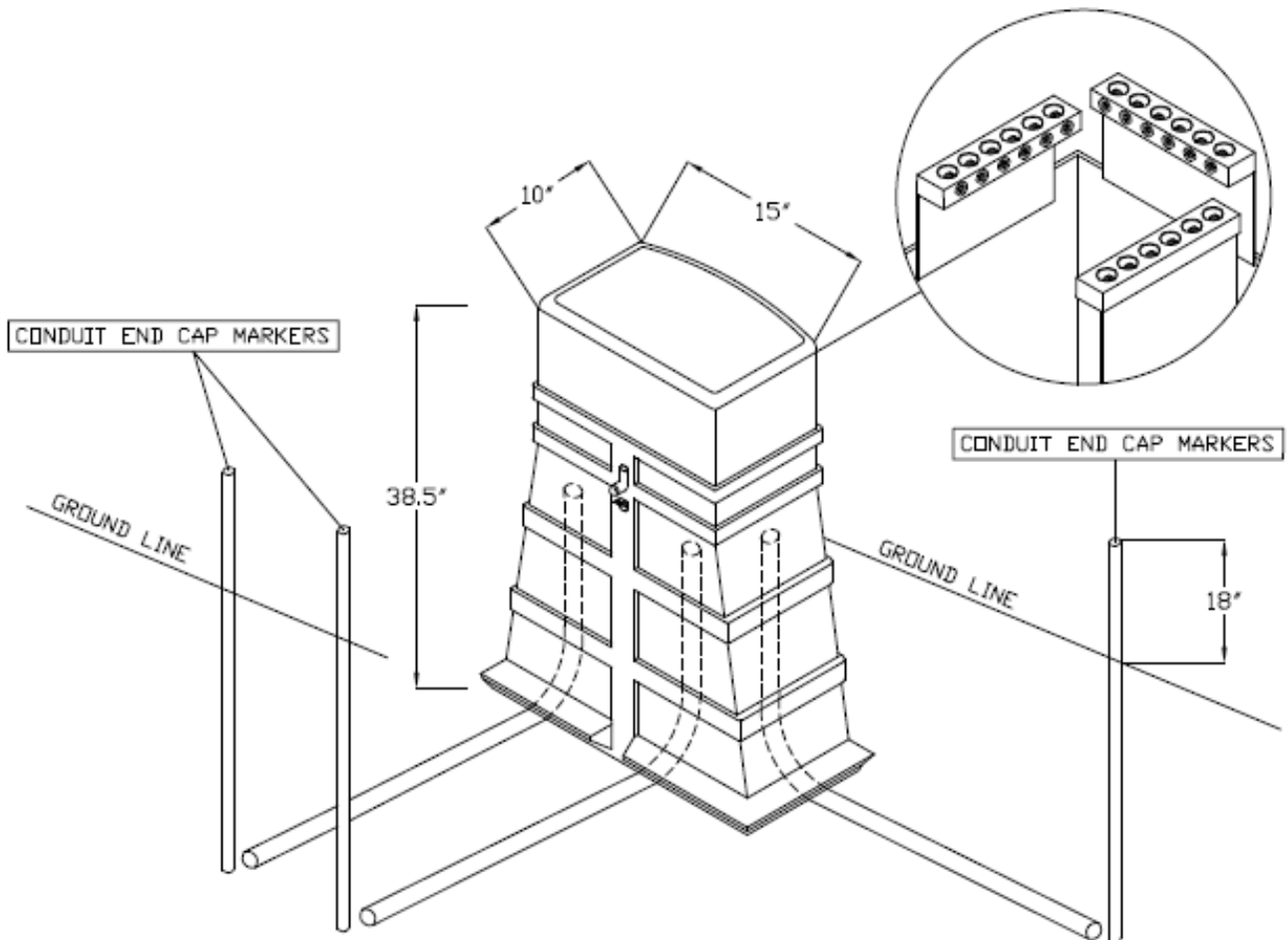

**SV2104**      1-PE SECONDARY PEDESTAL, 10" X 15" X 38"  
 (W/ #12-350MCM IN-LAY CONNECTOR BLOCKS)

OEU STOCK NO.	DESCRIPTION	QTY
E14-25-0110	VAULT, PEDESTAL SECONDARY 1-PHASE 10"X15"X38"	1

REVISED DATE: FEBRUARY 7, 2023

REVISED BY: FRANK BROWN

APPROVED BY: RANDY HAHN

## COMMERCIAL & RESIDENTIAL CONDUIT POLICY

### TYPICAL SECONDARY PEDESTAL LOCATION

#### EXHIBIT 15



OCALA ELECTRIC UTILITY STANDARDS

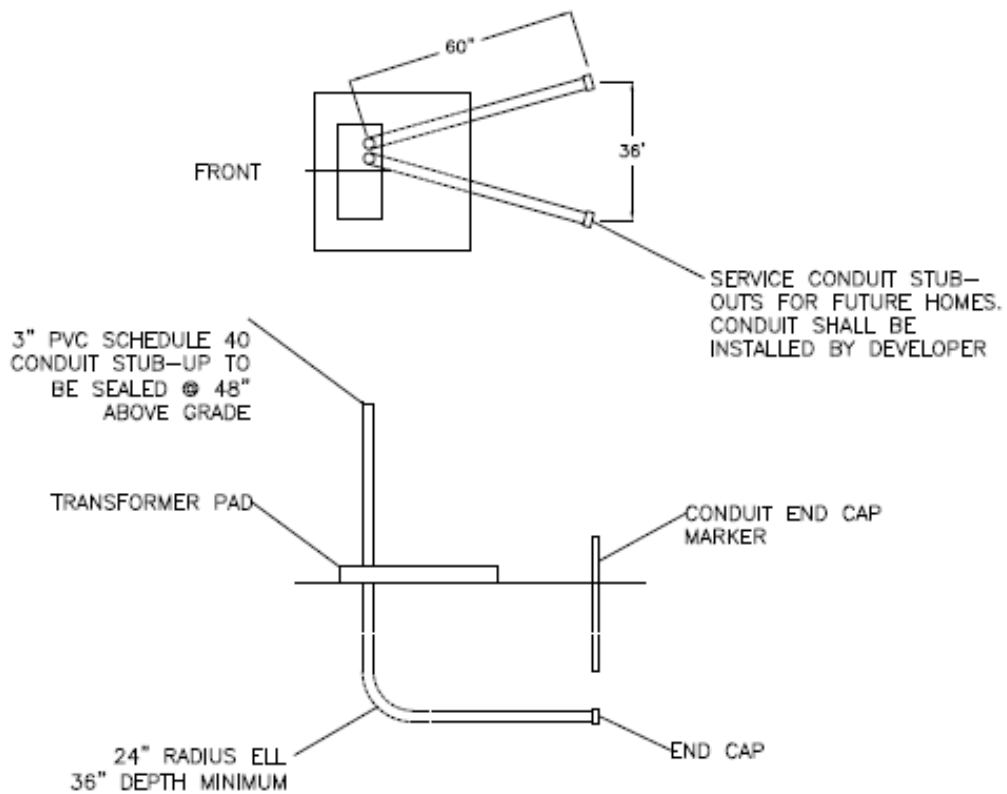
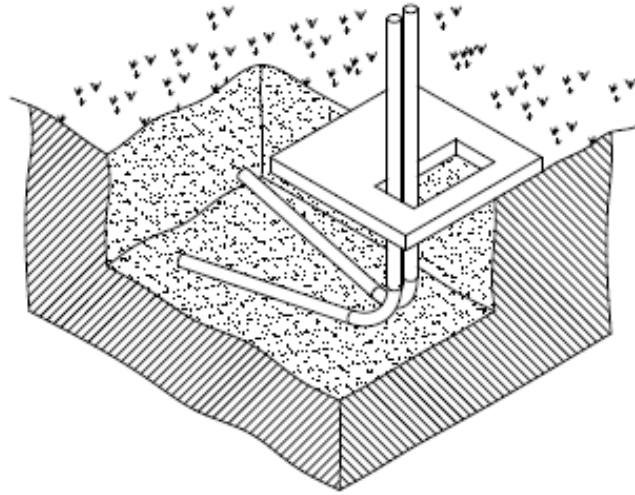

REVISED DATE: FEBRUARY 1, 2023

REVISED BY: FRANK BROWN

APPROVED BY: RANDY HAHN

COMMERCIAL & RESIDENTIAL CONDUIT POLICY

SERVICE STUB-OUTS AT TRANSFORMER (FUTURE USE)

EXHIBIT 17



# OCALA ELECTRIC UTILITY STANDARDS

**TEMP AT TRANSFORMER**  
Front View

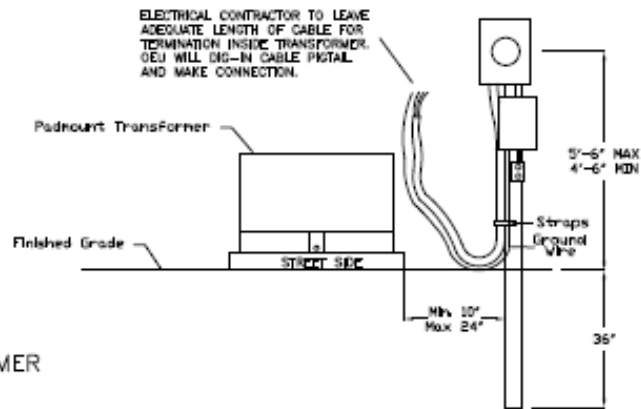

**TEMP AT TRANSFORMER**  
3-D View

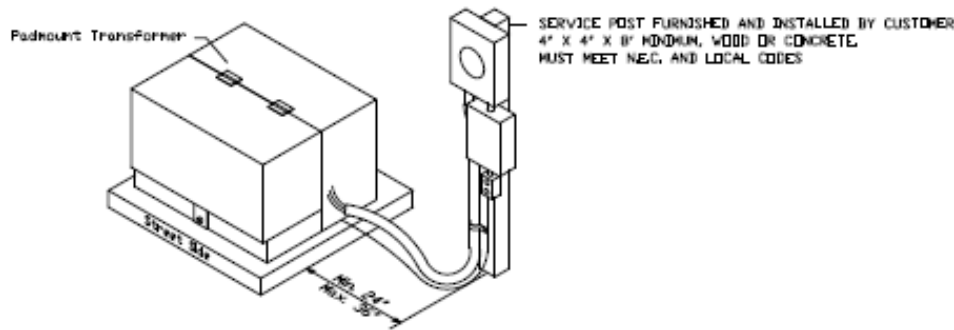

**TRANSFORMER + SECONDARY VAULT**  
3-D View

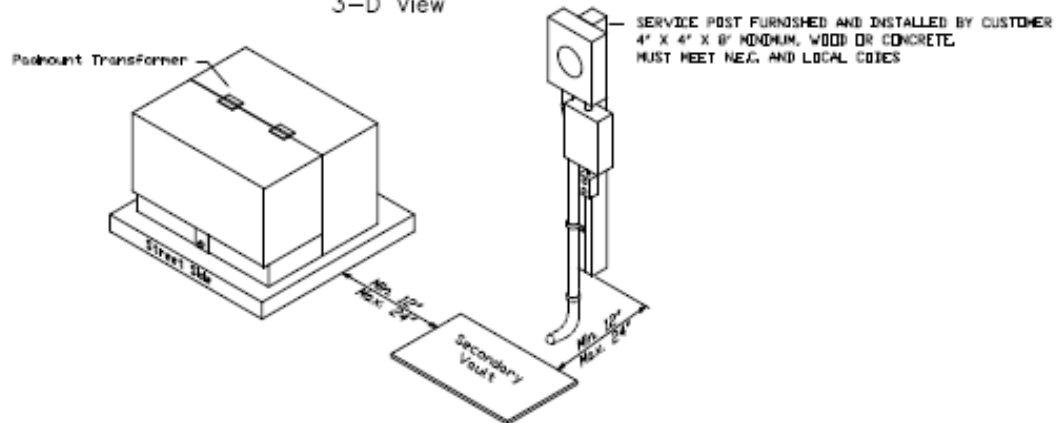

**NOTES:**

1. CABLE LOCATION REQUIRED PRIOR TO INSTALLATION OF TEMPORARY CONSTRUCTION POLE. CALL 48 HOURS IN ADVANCE.
2. OEU WILL MAKE FINAL CONNECTION OF CUSTOMER'S TEMP SERVICE CABLE IN TRANSFORMER OR SECONDARY VAULT.
3. DO NOT PULL TEMP SERVICE CABLE INTO TRANSFORMER THROUGH SERVICE STUB-OUTS.

REVISED DATE: FEBRUARY 1, 2023

REVISED BY: FRANK BROWN

APPROVED BY: RANDY HAHN

## COMMERCIAL & RESIDENTIAL CONDUIT POLICY

### TEMP SERVICE AT TRANSFORMER OR SECONDARY VAULT

#### EXHIBIT 18

# OCALA ELECTRIC UTILITY STANDARDS

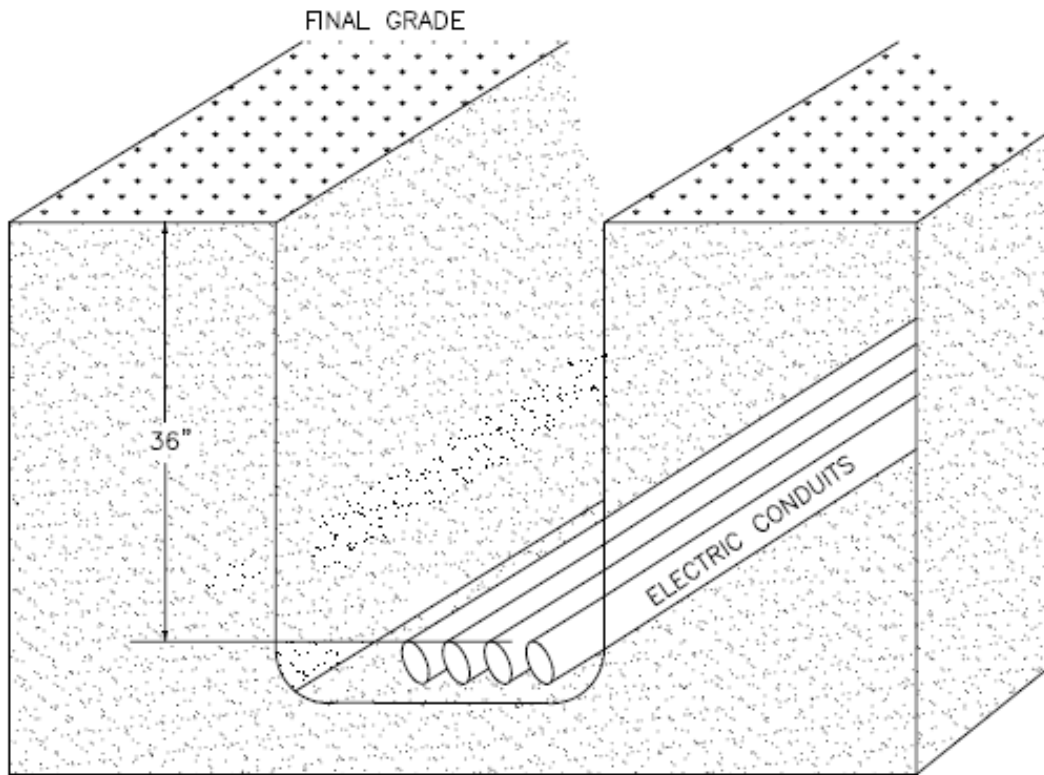

*When more than one conduit is being installed in a trench, no stacking of conduits is permitted. All conduits must lay flat in the trench.*

REVISED DATE: FEBRUARY 1, 2023

REVISED BY: FRANK BROWN

APPROVED BY: RANDY HAHN

## COMMERCIAL & RESIDENTIAL CONDUIT POLICY

### MULTIPLE CONDUITS IN TRENCH

#### EXHIBIT 19

# Ocala Electric Utility Standards

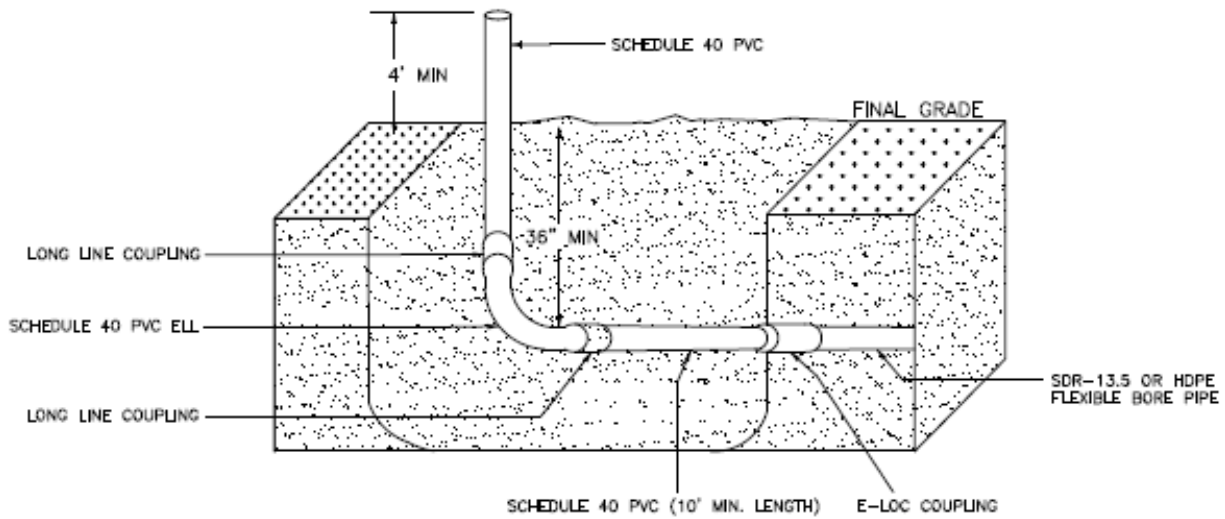

REVISED DATE: FEBRUARY 6, 2023

REVISED BY: FRANK BROWN

APPROVED BY: RANDY HAHN

## COMMERCIAL & RESIDENTIAL CONDUIT POLICY

### SDR-13.5 OR HDPE FLEXIBLE BORE PIPE STUB-UPS

#### EXHIBIT 20

# OCALA ELECTRIC UTILITY STANDARDS

## RESIDENTIAL METER SOCKET SPACING REQUIREMENTS

3-WIRE, OH/UG SERVICE (120/240V OR 120/208V, 400 AMP OR LESS)

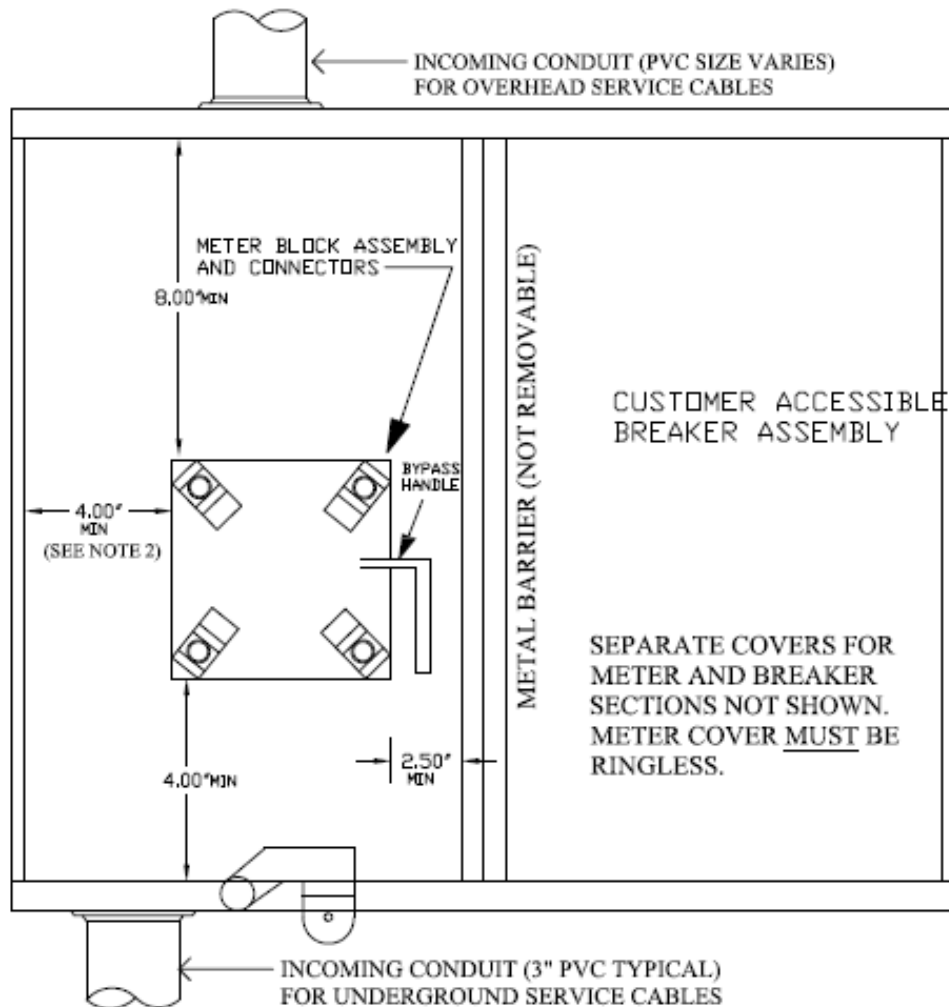

### NOTES:

1. IF THE SOCKET IS USED FOR U.G. SERVICE AND IS BUILT WITH NO OBSTRUCTION TO FULL DEPTH ON EITHER SIDE OF THE BLOCK ASSEMBLY AREA, (SEE BOLD SQUARE IN DRAWING), MIN 4.00' CLEARANCE TO LEFT SIDE, AND MIN 2.5' CLEARANCE TO RIGHT SIDE IS ACCEPTABLE (AS SHOWN) PROVIDED 3.00' OF UNOBSTRUCTED DEPTH IS ALSO MADE AVAILABLE AT BOTH SIDES OF SOCKET BLOCKS FOR LINE SIDE CONDUCTORS.
2. IF LINE CONDUCTORS COME IN FROM THE TOP OF THE SOCKET, SIDE TO BLOCK CLEARANCE MAY BE REDUCED TO 2.5' WITH 3' OBSTRUCTION DEPTH AT THAT SIDE, AND 2.5' BLOCK CLEARANCE TO THE OTHER SIDE.
3. SOCKET MUST ACCEPT 3" SCHEDULE 40 PVC AT BOTTOM.
4. BYPASS HORNS ARE NOT ACCEPTABLE.
5. METER HOUSING MUST BE GROUNDED.
6. 5TH TERMINAL REQUIRED IF USED ON 3-WIRE 120/208V SERVICE.

REVISED DATE: FEBRUARY 6, 2023

REVISED BY: FRANK BROWN

APPROVED BY: RANDY HAHN

## COMMERCIAL & RESIDENTIAL CONDUIT POLICY

### METER SOCKET SPACING REQUIREMENTS

#### EXHIBIT 21

# ACCEPTABLE FOR UNDERGROUND SERVICE

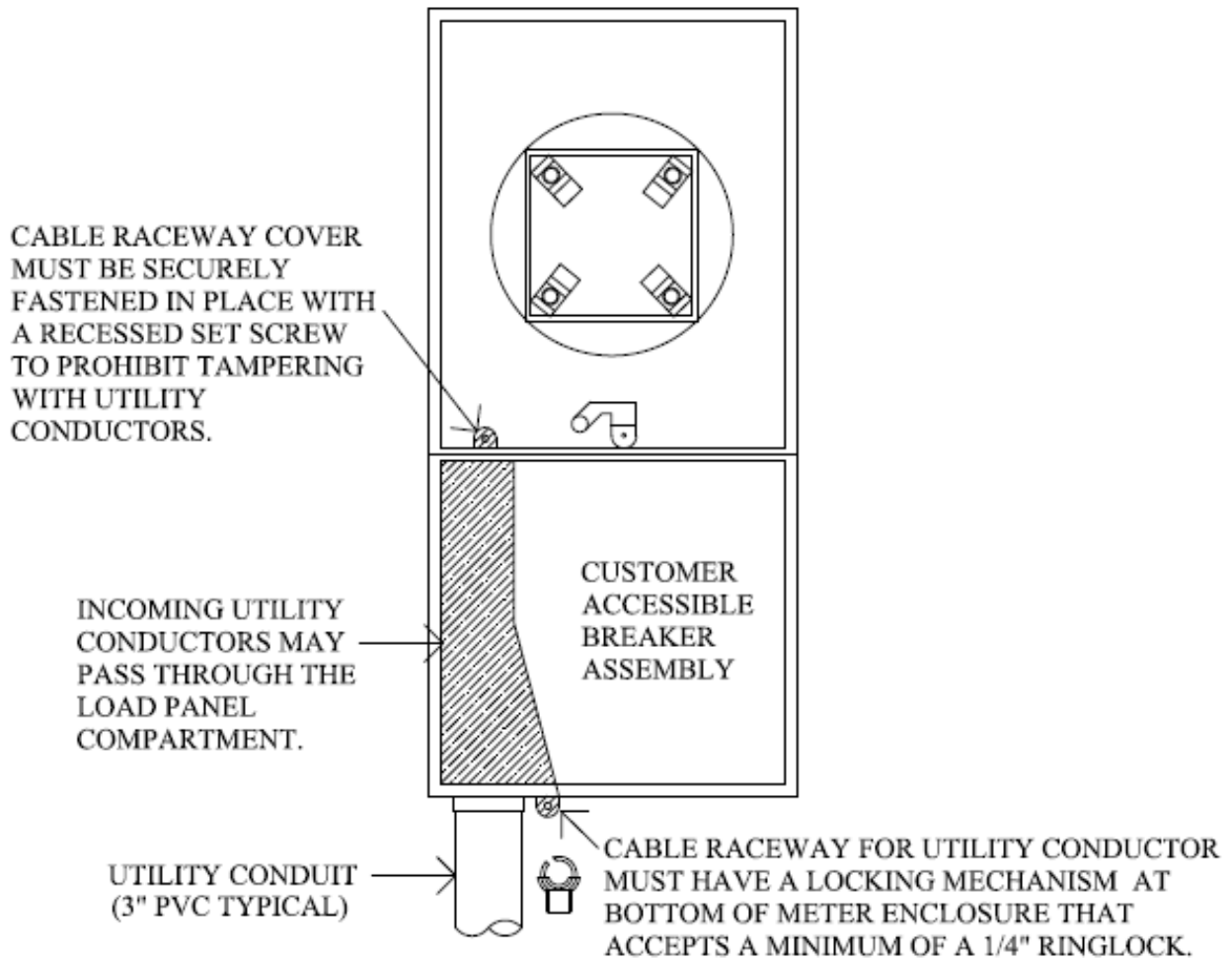

3-WIRE, UG SERVICE, (120/240V OR 120/208V)  
CUSTOMER OWNED METER SOCKET

REVISED DATE: FEBRUARY 6, 2023

REVISED BY: FRANK BROWN

APPROVED BY: RANDY HAHN

COMMERCIAL & RESIDENTIAL CONDUIT POLICY

COMBINATION METER SOCKET W/ BREAKER PANEL

EXHIBIT 22

# OCALA ELECTRIC UTILITY STANDARDS

## SECONDARY / SERVICE CONDUIT FROM RISER POLE TO METER SOCKET (S)

**NOTES:**

- RESIDENTIAL SERVICE CONDUCTORS FOR 1-2 FAMILY DWELLINGS SHALL BE INSTALLED BY Ocala Electric Utility FROM THE RISER POLE TO THE LINE SIDE TERMINALS OF THE METER SOCKET.
- LOAD CONDUCTORS SHALL BE CONNECTED TO THE LOAD SIDE TERMINALS OF THE METER SOCKET BY THE CUSTOMER'S ELECTRICIAN.
- SECONDARY AND SERVICE CONDUIT SHALL BE SUPPLIED AND INSTALLED BY THE CUSTOMER'S ELECTRICIAN.
- SERVICE RISER CONDUIT SHALL BE INSTALLED FLAT AGAINST THE OUTER WALL OF THE DWELLING AND MUST BE ANCHORED.
- BENDS IN THE CONDUIT RUN SHALL BE MADE WITH MANUFACTURED 45 OR 90-DEGREE ELLS CONNECTED BY LONG LINE COUPLINGS. HEATING AND BENDING OF CONDUIT TO FORM ELLS IS NOT ACCEPTABLE.
- 90-DEGREE ELBOWS MUST BE AT LEAST 24" RADIUS, SCHEDULE 40 PVC.
- A MAXIMUM OF THREE (3) 90-DEGREE ELBOWS (270-DEGREES TOTAL) IS PERMITTED IN ANY RUN OF CONDUIT.

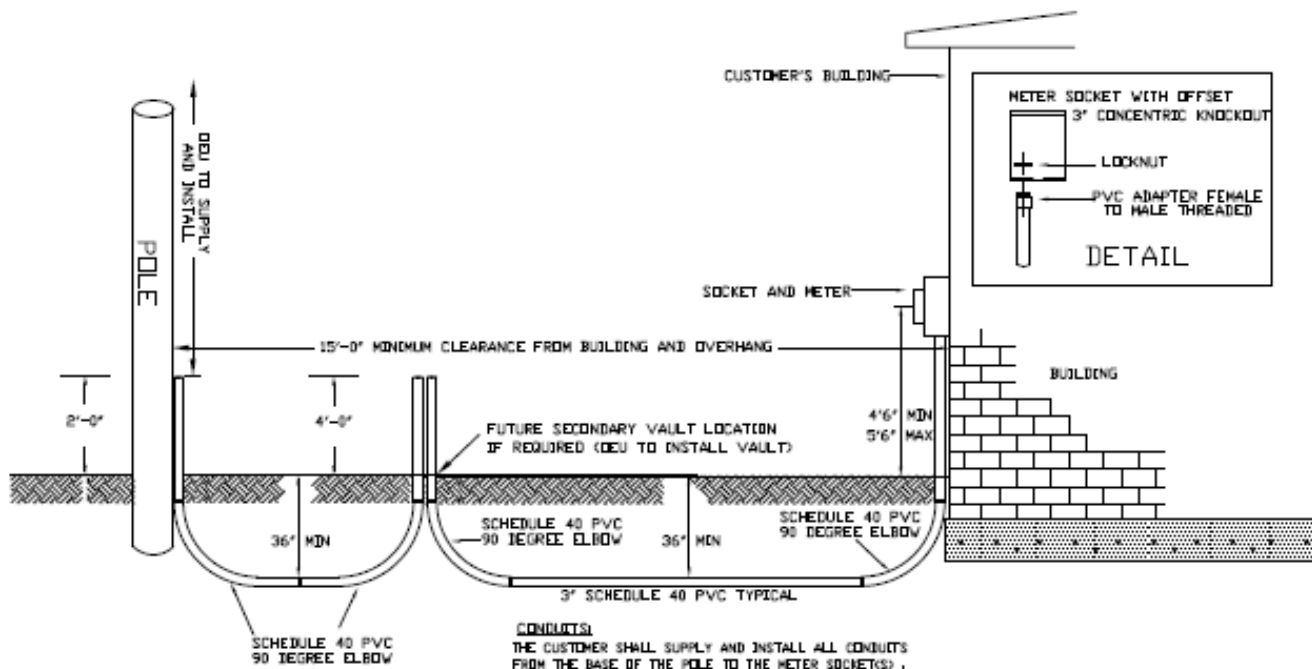

REVISED DATE: FEBRUARY 6, 2023

REVISED BY: FRANK BROWN

APPROVED BY: RANDY HAHN

### COMMERCIAL & RESIDENTIAL CONDUIT POLICY

### SECONDARY/SERVICE CONDUIT INSTALLATION FROM RISER POLE

#### EXHIBIT 23

# OCALA ELECTRIC UTILITY STANDARDS

## SECONDARY / SERVICE CONDUIT FROM PADMOUNT TRANSFORMER TO METER SOCKET (S)

### NOTES:

- RESIDENTIAL SERVICE CONDUCTORS FOR 1-2 FAMILY DWELLINGS SHALL BE INSTALLED BY OCALA ELECTRIC UTILITY FROM THE RISER POLE TO THE LINE SIDE TERMINALS OF THE METER SOCKET.
- LOAD CONDUCTORS SHALL BE CONNECTED TO THE LOAD SIDE TERMINALS OF THE METER SOCKET BY THE CUSTOMER'S ELECTRICIAN.
- SECONDARY AND SERVICE CONDUIT SHALL BE SUPPLIED AND INSTALLED BY THE CUSTOMER'S ELECTRICIAN.
- SERVICE RISER CONDUIT SHALL BE INSTALLED FLAT AGAINST THE OUTER WALL OF THE DWELLING AND MUST BE ANCHORED.
- BENDS IN THE CONDUIT RUN SHALL BE MADE WITH MANUFACTURED 45 OR 90-DEGREE ELLS CONNECTED BY LONG LINE COUPLINGS. HEATING AND BENDING OF CONDUIT TO FORM ELLS IS NOT ACCEPTABLE.
- 90-DEGREE ELBOWS MUST BE AT LEAST 24" RADIUS, SCHEDULE 40 PVC.
- A MAXIMUM OF THREE (3) 90-DEGREE ELBOWS (270-DEGREES TOTAL) IS PERMITTED IN ANY RUN OF CONDUIT.

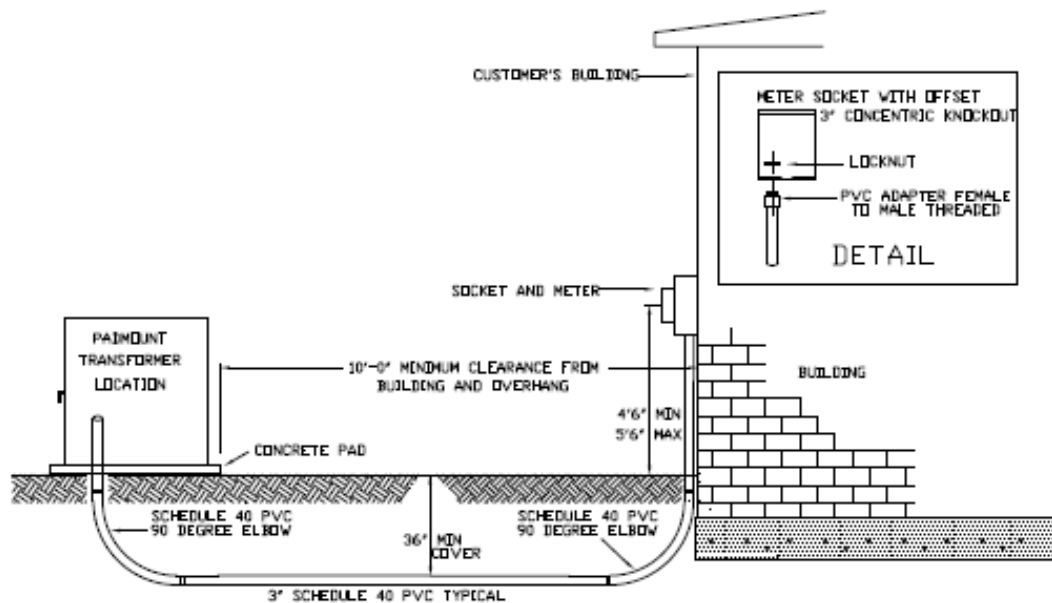

### CONDUITS:

THE CUSTOMER SHALL SUPPLY AND INSTALL ALL CONDUITS FROM THE PADMOUNT TRANSFORMER TO THE METER SOCKET(S).

REVISED DATE: FEBRUARY 6, 2023

REVISED BY: FRANK BROWN

APPROVED BY: RANDY HAHN

## COMMERCIAL & RESIDENTIAL CONDUIT POLICY

### SECONDARY/SERVICE CONDUIT INSTALLATION FROM TRANSFORMER

#### EXHIBIT 24

# OCALA ELECTRIC UTILITY STANDARDS

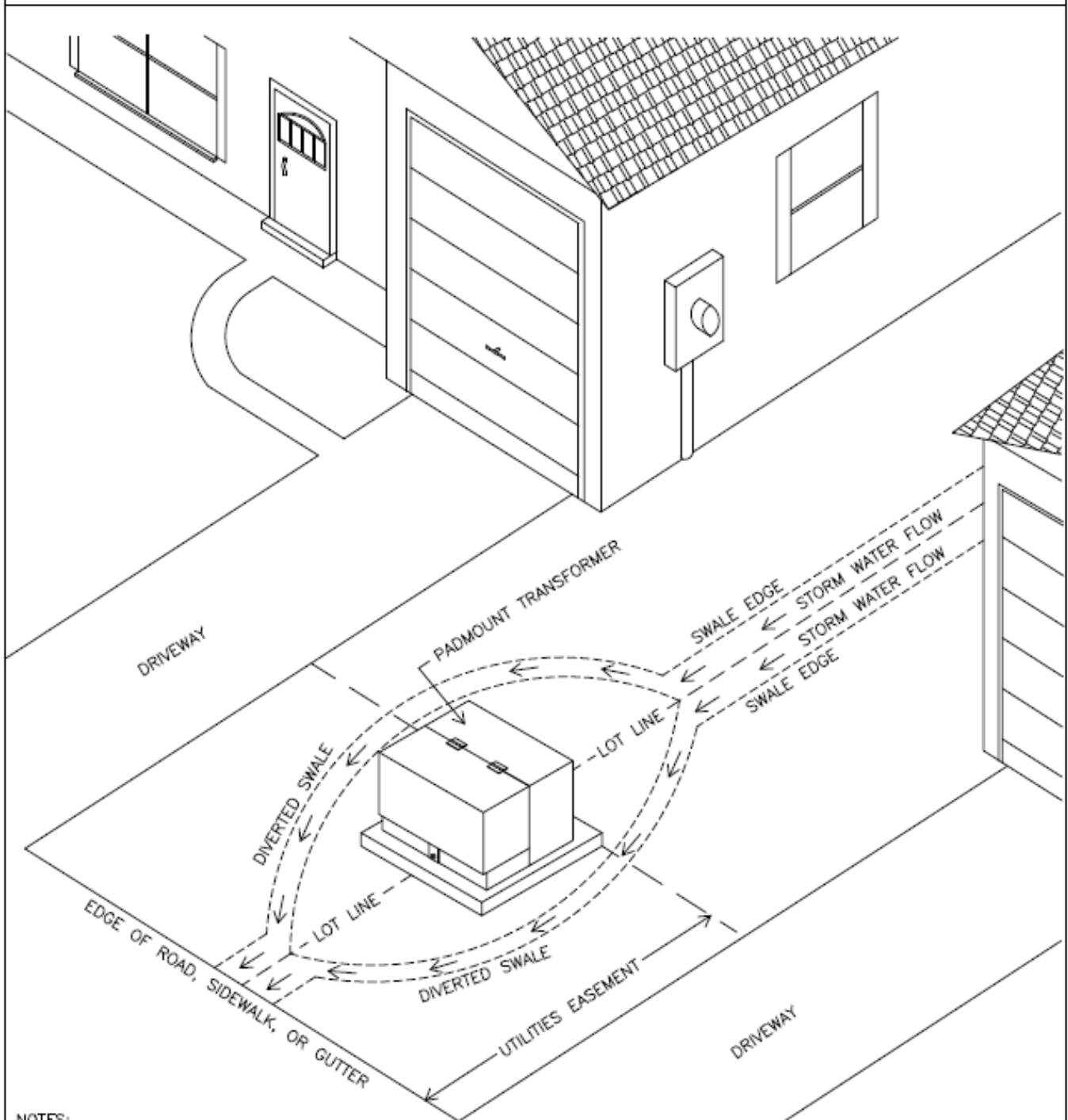

**NOTES:**

1. IF PADMOUNT TRANSFORMERS (OR OTHER EQUIPMENT) CANNOT BE OFFSET FROM THE LOT LINES DUE TO LACK OF AVAILABLE SPACE, THE DEVELOPER (OR CONSUMER) WILL BE RESPONSIBLE FOR DIVERTING STORM WATER FLOW PATTERNS AWAY FROM THE PADMOUNT TRANSFORMERS (OR EQUIPMENT) SO AS TO PREVENT WATER DAMAGE.
2. IF STORM WATER SWALE DIVERSION IS NECESSARY, THE DEVELOPER (OR CONSUMER) MUST PROVIDE THE DIVERSION PLAN. THE DIVERSION PLAN MUST BE APPROVED BY OEU ENGINEERING DIVISION PRIOR TO ENERGIZATION OF THAT EQUIPMENT.

REVISED DATE: FEBRUARY 6, 2023

REVISED BY: FRANK BROWN

APPROVED BY: RANDY HAHN

## COMMERCIAL & RESIDENTIAL CONDUIT POLICY

### STORM WATER DIVERSION FOR PADMOUNT EQUIPMENT

#### EXHIBIT 25



## OCALA ELECTRIC UTILITY STANDARDS

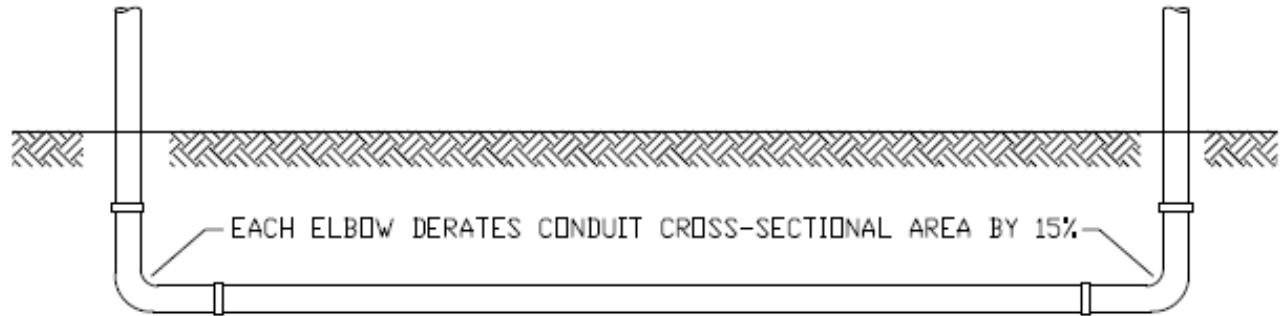

### 15KV PRIMARY CABLE CONDUIT SIZING CHART

PRIMARY CABLE SIZE	# OF CABLES IN CONDUIT	# OF ELBOWS IN CONDUIT	MIN. CONDUIT SIZE
1/0 AL 220 EPR	1	1-3	3" SCHEDULE 40
4/0 AL 220 EPR	1	1-3	3" SCHEDULE 40
500 AL 220 EPR	1	1-2	3" SCHEDULE 40
500 AL 220 EPR	1	3	4" SCHEDULE 40
750 AL 220 EPR	1	1	3" SCHEDULE 40
750 AL 220 EPR	1	2-3	4" SCHEDULE 40
1000 AL 175 EPR	1	1	3" SCHEDULE 40
1000 AL 175 EPR	1	2-3	4" SCHEDULE 40
1/0 AL 220 EPR	2	1-3	4" SCHEDULE 40
4/0 AL 220 EPR	2	1-2	4" SCHEDULE 40
4/0 AL 220 EPR	2	3	6" SCHEDULE 40
1/0 AL 220 EPR	3	1-2	4" SCHEDULE 40
1/0 AL 220 EPR	3	3	6" SCHEDULE 40
4/0 AL 220 EPR	3	1	4" SCHEDULE 40
4/0 AL 220 EPR	3	2-3	6" SCHEDULE 40
500 AL 220 EPR	3	1-2	6" SCHEDULE 40
500 AL 220 EPR	3	3	8" SCHEDULE 40
750 AL 220 EPR	3	1	6" SCHEDULE 40
750 AL 220 EPR	3	2-3	8" SCHEDULE 40
1000 AL 175 EPR	3	1-3	8" SCHEDULE 40

REVISED DATE: FEBRUARY 6, 2023

REVISED BY: FRANK BROWN

APPROVED BY: RANDY HAHN

### COMMERCIAL & RESIDENTIAL CONDUIT POLICY

### 15KV PRIMARY CABLE CONDUIT SIZING CHART

EXHIBIT 26

## OCALA ELECTRIC UTILITY STANDARDS

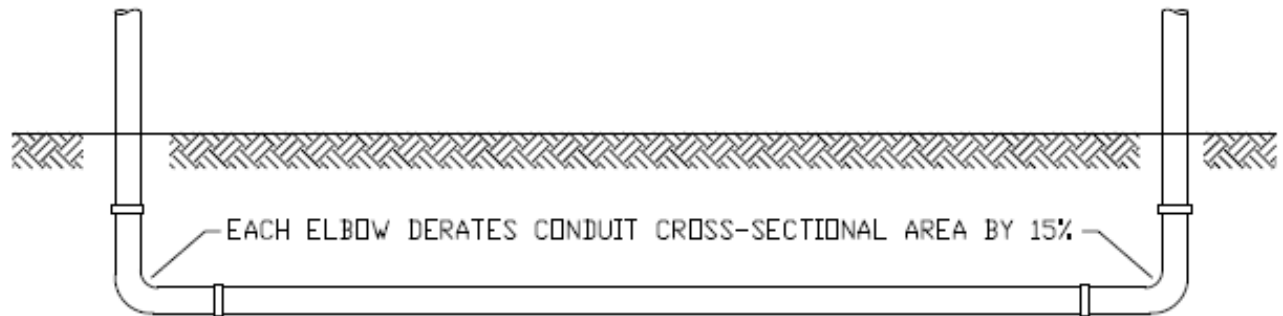

### 600V MULTI-PLEX CABLE CONDUIT SIZING CHART

SERVICE CABLE SIZE	# OF CABLES IN CONDUIT	# OF ELBOWS IN CONDUIT	MIN. CONDUIT SIZE
#12-2C w/ Ground	1	1-3	1" SCHEDULE 40
#6-3C Erskine	1	1	1" SCHEDULE 40
#6-3C Erskine	1	2-3	1.25" SCHEDULE 40
1/0-3C Brenau	1	1-3	2" SCHEDULE 40
4/0-3C Sweetbriar	1	1-3	3" SCHEDULE 40
350-3C Wesleyan	1	1-2	3" SCHEDULE 40
350-3C Wesleyan	1	3	4" SCHEDULE 40
4/0-4C Wake Forest	1	1-3	3" SCHEDULE 40
350-4C SlipperyRock	1	1	3" SCHEDULE 40
350-4C SlipperyRock	1	2-3	4" SCHEDULE 40

NOTE: ONLY ONE (1) MULTI-PLEX CABLE PER CONDUIT ALLOWED.

REVISED DATE: FEBRUARY 6, 2023

REVISED BY: FRANK BROWN

APPROVED BY: RANDY HAHN

### COMMERCIAL & RESIDENTIAL CONDUIT POLICY

### 600V MULTI-PLEX CABLE CONDUIT SIZING CHART

**EXHIBIT 27**

## OCALA ELECTRIC UTILITY STANDARDS

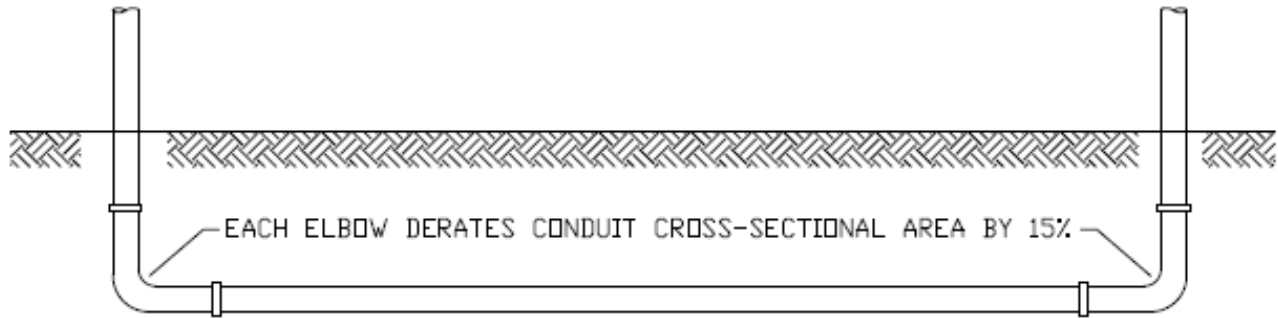

### 600V THHN-AL CABLE CONDUIT SIZING CHART

THHN CABLE SIZE	# OF CABLES IN CONDUIT	# OF ELBOWS IN CONDUIT	MIN. CONDUIT SIZE
#2-7 Str AL	3	1-3	1.25' SCHEDULE 40
1/0-18 Str AL	3	1-2	1.5' SCHEDULE 40
1/0-18 Str AL	3	3	2' SCHEDULE 40
2/0-18 Str AL	3	1-2	1.5' SCHEDULE 40
2/0-18 Str AL	3	3	2' SCHEDULE 40
3/0-18 Str AL	3	1-3	2' SCHEDULE 40
4/0-18 Str AL	3	1-2	2' SCHEDULE 40
4/0-18 Str AL	3	3	2.5' SCHEDULE 40
250-22 Str AL	3	1-3	2.5' SCHEDULE 40
350-35 Str AL	3	1-2	2.5' SCHEDULE 40
350-35 Str AL	3	3	3' SCHEDULE 40
1/0-18 Str AL	4	1-3	2' SCHEDULE 40
2/0-18 Str AL	4	1-3	2.5' SCHEDULE 40
3/0-18 Str AL	4	1-3	2.5' SCHEDULE 40
4/0-18 Str AL	4	1-3	3' SCHEDULE 40
250-22 Str AL	4	1-3	3' SCHEDULE 40
350-35 Str AL	4	1-3	4' SCHEDULE 40
500-35 Str AL	4	1-3	4' SCHEDULE 40
750-58 Str AL	4	1-3	5' SCHEDULE 40
1000-58 Str AL	4	1-3	6' SCHEDULE 40

**NOTES:**

- 1.) 3 CABLES IN CONDUIT = 2 PHASE WIRES + NEUTRAL
- 2.) 4 CABLES IN CONDUIT = 3 PHASE WIRES + NEUTRAL

REVISED DATE: FEBRUARY 6, 2023

REVISED BY: FRANK BROWN

APPROVED BY: RANDY HAHN

### COMMERCIAL & RESIDENTIAL CONDUIT POLICY

### 600V THHN-AL CABLE CONDUIT SIZING CHART

#### EXHIBIT 28

## OCALA ELECTRIC UTILITY STANDARDS

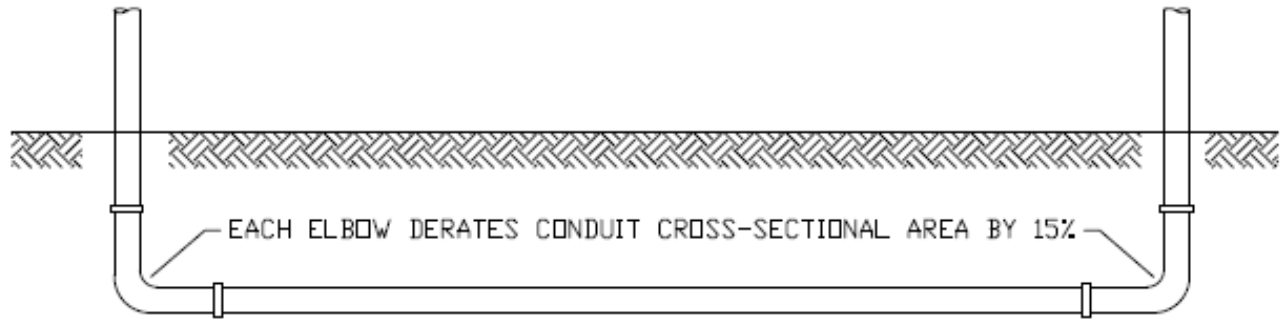

### 600V THHN-CU CABLE CONDUIT SIZING CHART

THHN CABLE SIZE	# OF CABLES IN CONDUIT	# OF ELBOWS IN CONDUIT	MIN. CONDUIT SIZE
#2-19 Str CU	3	1-2	1.25" SCHEDULE 40
#2-19 Str CU	3	3	1.5" SCHEDULE 40
1/0-19 Str CU	3	1-2	1.5" SCHEDULE 40
1/0-19 Str CU	3	3	2" SCHEDULE 40
2/0-19 Str CU	3	1-3	2" SCHEDULE 40
3/0-19 Str CU	3	1-2	2" SCHEDULE 40
3/0-19 Str CU	3	3	2.5" SCHEDULE 40
4/0-19 Str CU	3	1-2	2" SCHEDULE 40
4/0-19 Str CU	3	3	2.5" SCHEDULE 40
250-37 Str CU	3	1-2	2.5" SCHEDULE 40
250-37 Str CU	3	3	3" SCHEDULE 40
350-37 Str CU	3	1-3	3" SCHEDULE 40
1/0-19 Str CU	4	1-3	2" SCHEDULE 40
2/0-19 Str CU	4	1-3	2.5" SCHEDULE 40
3/0-19 Str CU	4	1-3	2.5" SCHEDULE 40
4/0-19 Str CU	4	1-3	3" SCHEDULE 40
250-37 Str CU	4	1-3	3" SCHEDULE 40
350-37 Str CU	4	1-3	4" SCHEDULE 40
500-37 Str CU	4	1-3	4" SCHEDULE 40
750-61 Str CU	4	1-3	5" SCHEDULE 40
1000-61 Str CU	4	1-3	6" SCHEDULE 40

**NOTES:**

- 1.) 3 CABLES IN CONDUIT = 2 PHASE WIRES + NEUTRAL
- 2.) 4 CABLES IN CONDUIT = 3 PHASE WIRES + NEUTRAL

REVISED DATE: FEBRUARY 6, 2023

REVISED BY: FRANK BROWN

APPROVED BY: RANDY HAHN

### COMMERCIAL & RESIDENTIAL CONDUIT POLICY

### 600V THHN-CU CABLE CONDUIT SIZING CHART

**EXHIBIT 29**

# OCALA ELECTRIC UTILITY STANDARDS

## 45KVA – 1000KVA 120/208V, 120/240V, 277/480V PLAN VIEW

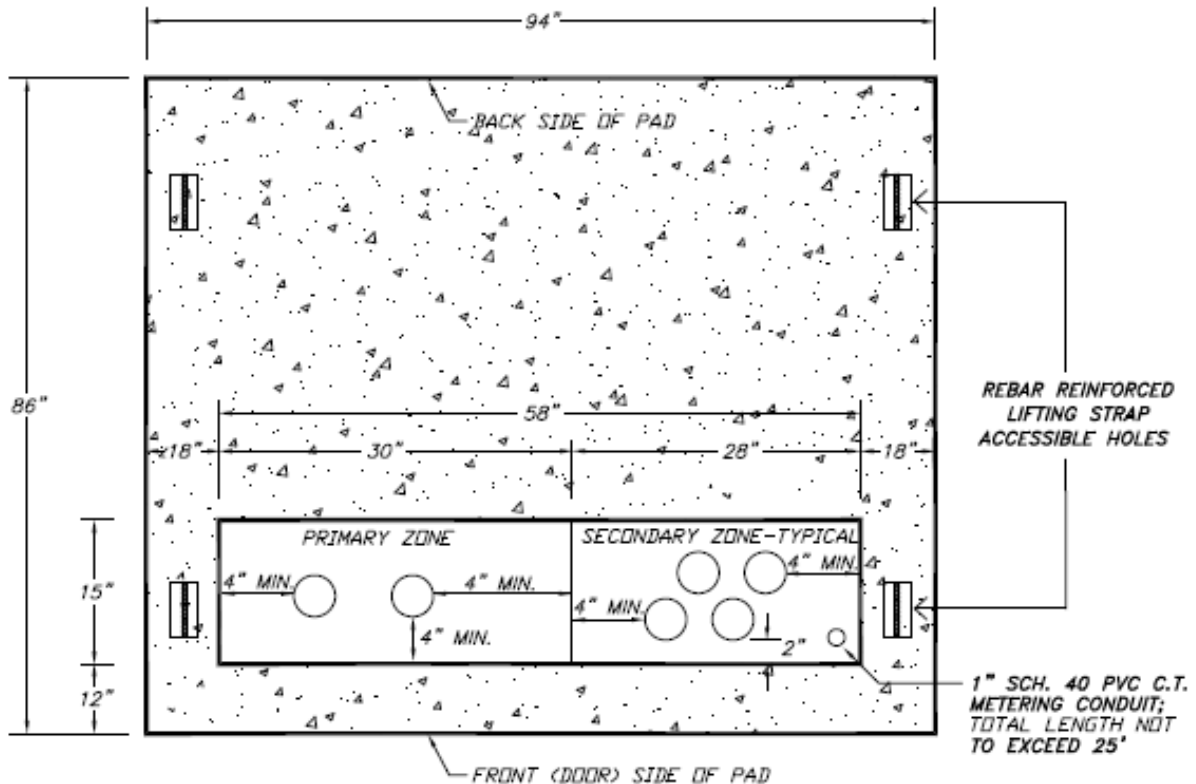

### ELEVATION VIEW

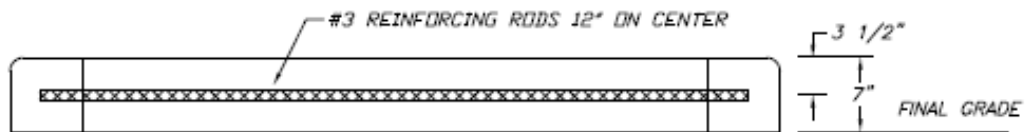

NOTE: CONCRETE TO BE 3000 PSI AT 28 DAYS

**NOTES:**

1. THE TRANSFORMER PAD MUST FACE IN THE DIRECTION SPECIFIED BY THE ELECTRIC ENGINEERING DIVISION. SHRUBS AND STRUCTURES MUST BE KEPT NINE (9) FEET AWAY FROM THE FRONT SIDE AND THREE (3) FEET AWAY FROM THE OTHER SIDES OF THE TRANSFORMER.
2. THE TRANSFORMER FORM MUST BE INSPECTED BY THE ELECTRIC ENGINEERING DIVISION, OEU OFFICE PHONE (352) 351-6620, PRIOR TO POURING CONCRETE. THE CONTRACTOR SHALL SCHEDULE THIS INSPECTION AT LEAST TWENTY FOUR (24) HOURS IN ADVANCE.
3. PRE-FABRICATED CONCRETE PADS MAY BE PURCHASED FROM OUTSIDE VENDORS AS LONG AS THE PRE-FABRICATED PADS MEET UTILITY SPECIFICATIONS.

REVISED DATE: FEBRUARY 6, 2023

REVISED BY: FRANK BROWN

APPROVED BY: RANDY HAHN

## COMMERCIAL & RESIDENTIAL CONDUIT POLICY

### 3-PHASE TRANSFORMER PAD DIMENSIONS (45-1000 KVA) EXHIBIT 30

OCALA ELECTRIC UTILITY STANDARDS

1500KVA – 2500KVA  
277/480V  
PLAN VIEW

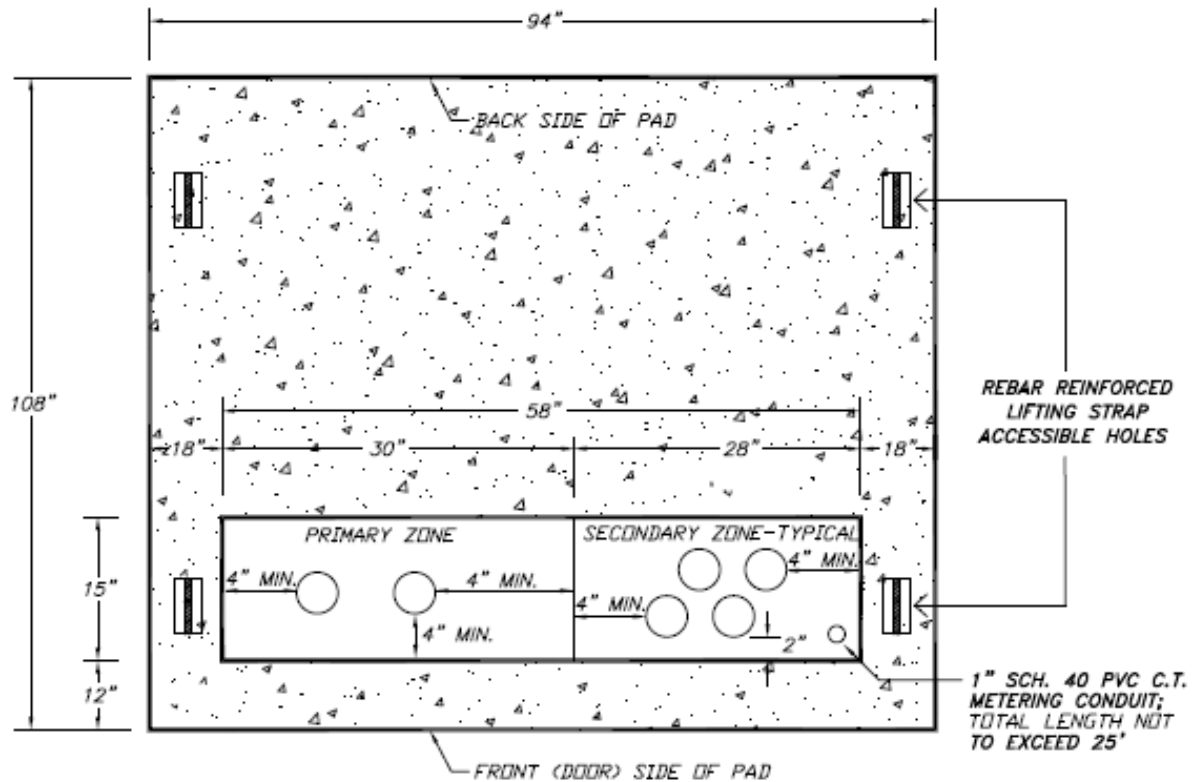

ELEVATION VIEW

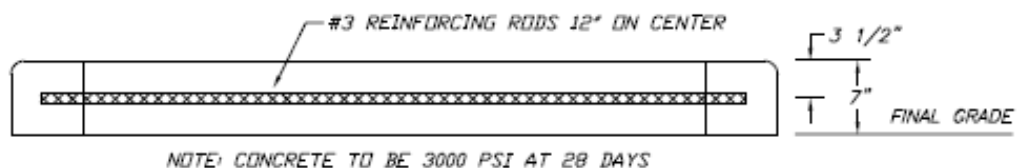

- NOTES:
1. THE TRANSFORMER MUST FACE IN THE DIRECTION SPECIFIED BY THE ELECTRIC ENGINEERING DIVISION. SHRUBS AND STRUCTURES MUST BE KEPT NINE (9) FEET AWAY FROM THE FRONT SIDE AND THREE (3) FEET AWAY FROM THE OTHER SIDES OF THE TRANSFORMER.
  2. THE TRANSFORMER FORM MUST BE INSPECTED BY THE ELECTRIC ENGINEERING DIVISION, OEU OFFICE PHONE (352) 351-6620, PRIOR TO POURING CONCRETE. THE CONTRACTOR SHALL SCHEDULE THIS INSPECTION AT LEAST TWENTY FOUR (24) HOURS IN ADVANCE.
  3. PRE-FABRICATED CONCRETE PADS MAY BE PURCHASED FROM OUTSIDE VENDORS AS LONG AS THE PRE-FABRICATED PADS MEET UTILITY SPECIFICATIONS.

REVISED DATE: FEBRUARY 6, 2023

REVISED BY: FRANK BROWN

APPROVED BY: RANDY HAHN

COMMERCIAL & RESIDENTIAL CONDUIT POLICY

3-PHASE TRANSFORMER PAD DIMENSIONS (1500-2500 KVA)

EXHIBIT 31

# OCALA ELECTRIC UTILITY STANDARDS

## PLAN VIEW

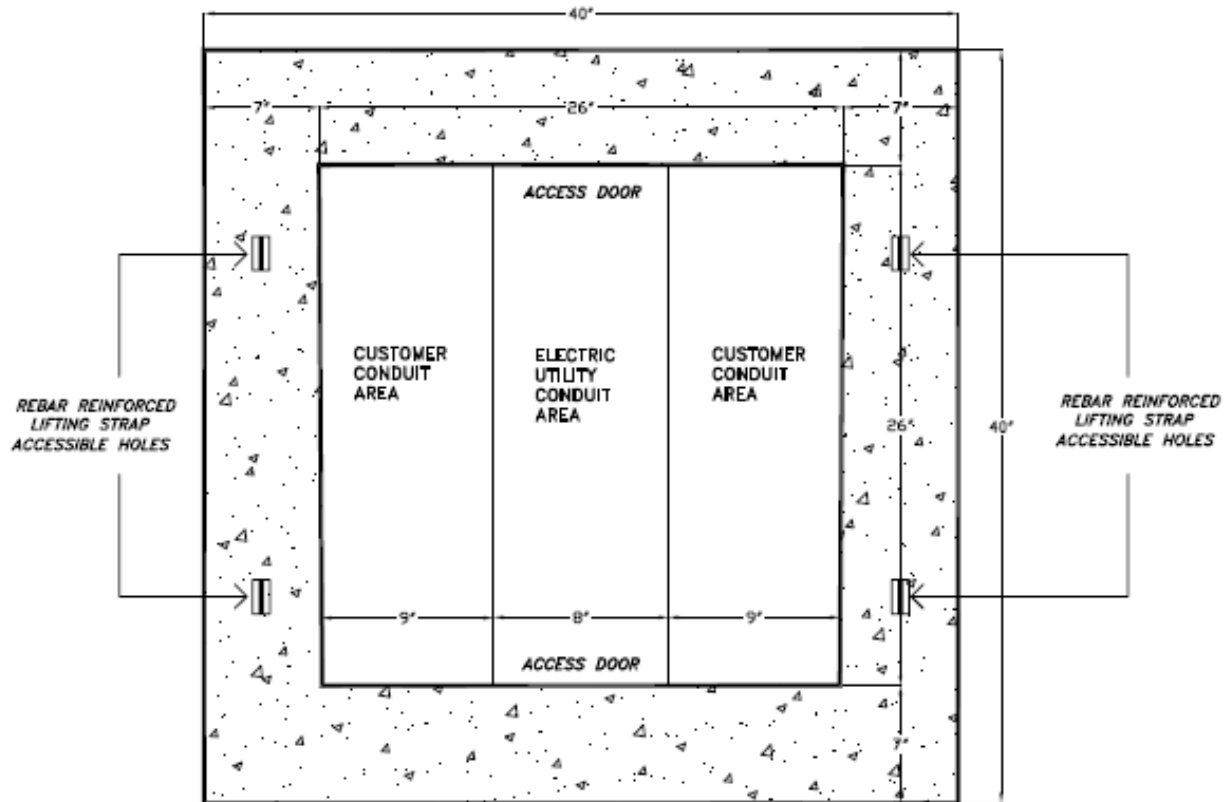

## ELEVATION VIEW

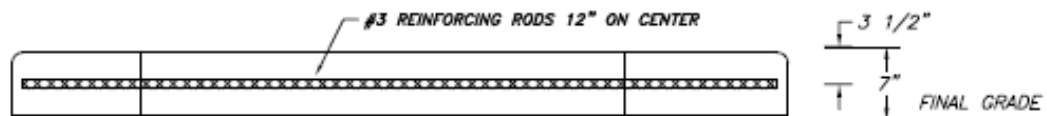

NOTE: CONCRETE TO BE 3000 PSI AT 28 DAYS

**NOTES:**

1. THE SECONDARY CABINET PAD MUST FACE IN THE DIRECTION SPECIFIED BY THE ELECTRIC ENGINEERING DIVISION.
2. SHRUBS AND STRUCTURES MUST BE KEPT SIX FEET AWAY FROM ALL SIDES OF THE SECONDARY CABINET PAD.
3. THE SECONDARY CABINET PAD FORM MUST BE INSPECTED BY THE ELECTRIC ENGINEERING DIVISION, OEU OFFICE PHONE (352) 351-6620, PRIOR TO POURING CONCRETE. THE CONTRACTOR SHALL SCHEDULE THIS INSPECTION AT A MINIMUM OF TWENTY FOUR (24) HOURS IN ADVANCE.
4. PRE-FABRICATED CONCRETE PADS MAY BE PURCHASED FROM OUTSIDE VENDORS AS LONG AS THE PRE-FABRICATED PADS MEET UTILITY SPECIFICATIONS.
5. THE CABINET PAD SHOULD BE PLACED AT A DISTANCE TO ACCOMODATE CONDUIT RADIUS-ELLS BETWEEN THE TRANSFORMER PAD AND THE CABINET PAD, BUT NO MORE THAN EIGHT (8) FEET FROM THE TRANSFORMER PAD.

REVISED DATE: AUGUST 23, 2023

REVISED BY: FRANK BROWN

APPROVED BY: RANDY HAHN

## COMMERCIAL & RESIDENTIAL CONDUIT POLICY

### 3-PHASE SECONDARY CABINET PAD DIMENSIONS (SMALL) EXHIBIT 32

# OCALA ELECTRIC UTILITY STANDARDS

## PLAN VIEW

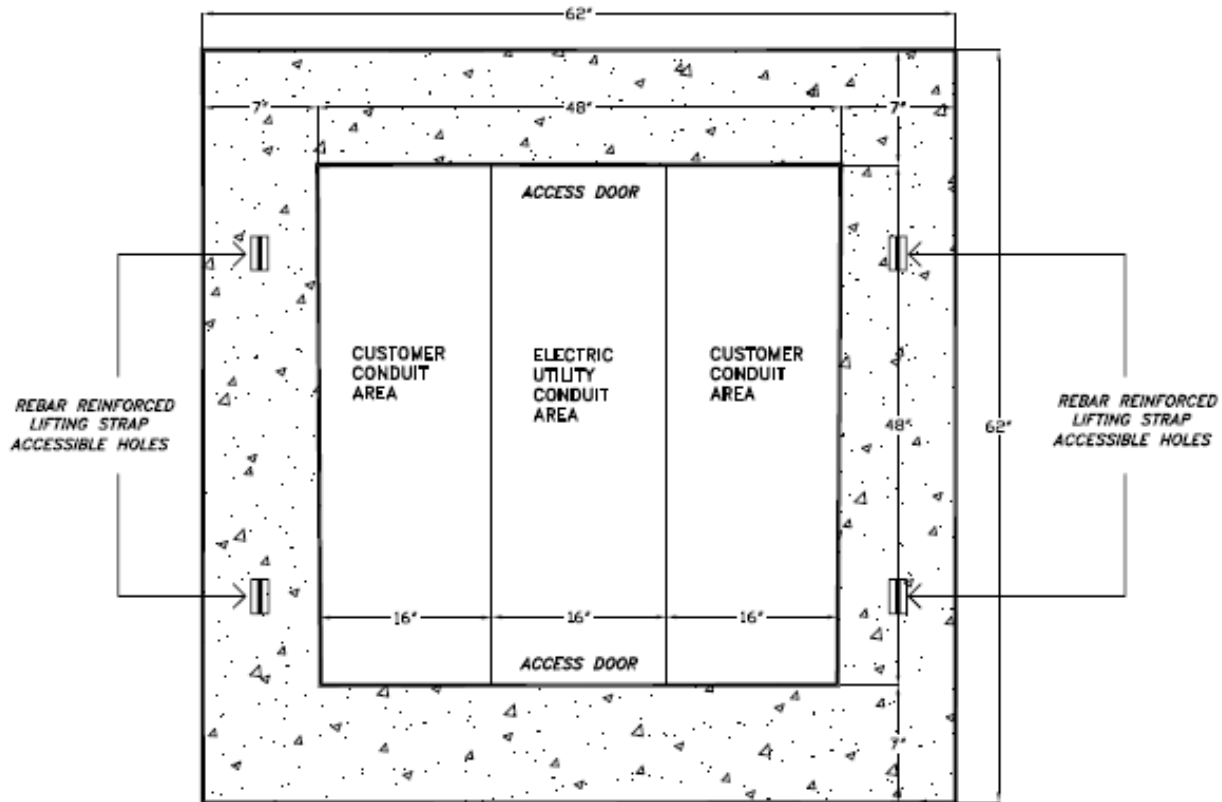

## ELEVATION VIEW

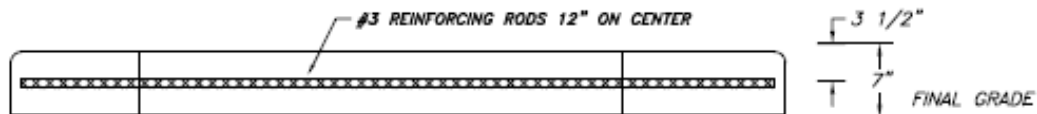

NOTE: CONCRETE TO BE 3000 PSI AT 28 DAYS

**NOTES:**

1. THE SECONDARY CABINET PAD MUST FACE IN THE DIRECTION SPECIFIED BY THE ELECTRIC ENGINEERING DIVISION.
2. SHRUBS AND STRUCTURES MUST BE KEPT SIX FEET AWAY FROM ALL SIDES OF THE SECONDARY CABINET PAD.
3. THE SECONDARY CABINET PAD FORM MUST BE INSPECTED BY THE ELECTRIC ENGINEERING DIVISION, OEU OFFICE PHONE (352) 351-8620, PRIOR TO POURING CONCRETE. THE CONTRACTOR SHALL SCHEDULE THIS INSPECTION AT A MINIMUM OF TWENTY FOUR (24) HOURS IN ADVANCE.
4. PRE-FABRICATED CONCRETE PADS MAY BE PURCHASED FROM OUTSIDE VENDORS AS LONG AS THE PRE-FABRICATED PADS MEET UTILITY SPECIFICATIONS.
5. THE CABINET PAD SHOULD BE PLACED AT A DISTANCE TO ACCOMMODATE CONDUIT RADIUS-ELLS BETWEEN THE TRANSFORMER PAD AND THE CABINET PAD, BUT NO MORE THAN EIGHT (8) FEET FROM THE TRANSFORMER PAD.

REVISED DATE: AUGUST 25, 2023

REVISED BY: FRANK BROWN

APPROVED BY: RANDY HAHN

## COMMERCIAL & RESIDENTIAL CONDUIT POLICY

### 3-PHASE SECONDARY CABINET PAD DIMENSIONS (LARGE)

EXHIBIT 33



# OCALA ELECTRIC UTILITY STANDARDS

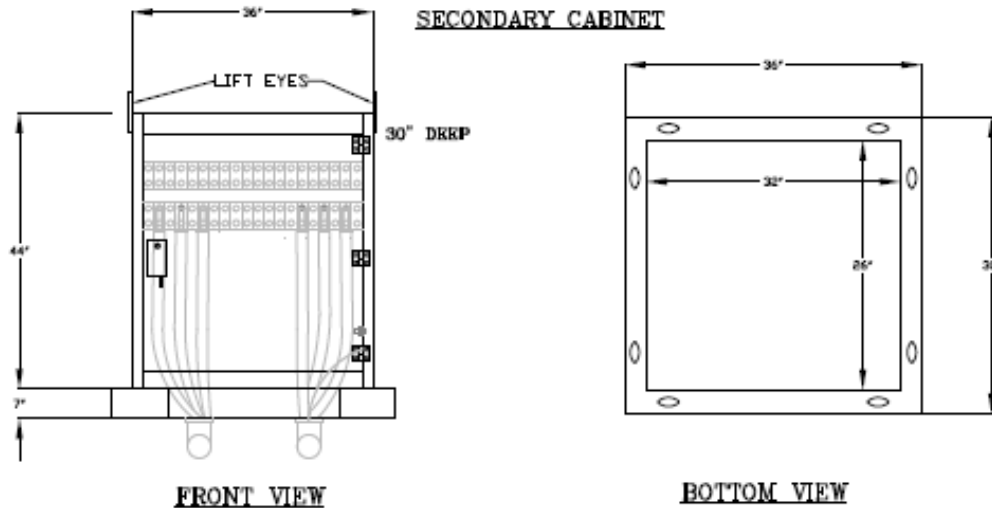

**SV2110** ENCLOSURE, TERMINATION, SECONDARY 3Ø

NO.	OUS STOCK NO.	DESCRIPTION	QTY	FERC
1	114-24-0180	ENCLOSURE TERMINATION SECONDARY	1	367

## SECONDARY CABINET CONCRETE PAD DIMENSIONS

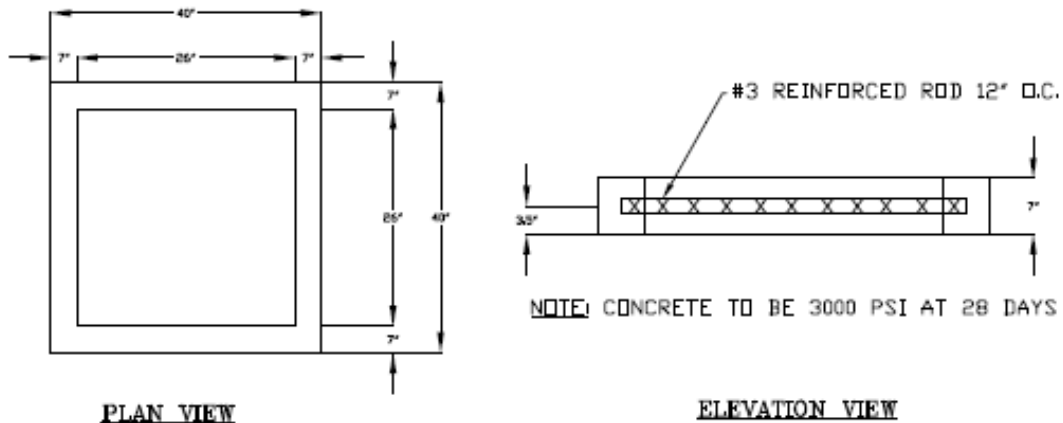

**NOTES:**

1. THE SECONDARY CABINET PAD MUST FACE IN THE DIRECTION SPECIFIED BY THE ELECTRIC ENGINEERING DIVISION.
2. SHRUBS AND STRUCTURES MUST BE KEPT SIX FEET AWAY FROM ALL SIDES OF THE SECONDARY CABINET PAD.
3. THE SECONDARY CABINET PAD FORM MUST BE INSPECTED BY THE ELECTRIC ENGINEERING DIVISION, OEU OFFICE PHONE (352) 351-6620, PRIOR TO POURING CONCRETE. THE CONTRACTOR SHALL SCHEDULE THIS INSPECTION AT A MINIMUM OF TWENTY FOUR (24) HOURS IN ADVANCE.
4. PRE-FABRICATED CONCRETE PADS MAY BE PURCHASED FROM OUTSIDE VENDORS AS LONG AS THE PRE-FABRICATED PADS MEET UTILITY SPECIFICATIONS.
5. THE CABINET PAD SHOULD BE PLACED AT A DISTANCE TO ACCOMODATE CONDUIT RADIUS-ELLS BETWEEN THE TRANSFORMER PAD AND THE CABINET PAD, BUT NO MORE THAN EIGHT (8) FEET FROM THE TRANSFORMER PAD.

REVISED DATE: AUGUST 23, 2023

REVISED BY: FRANK BROWN

APPROVED BY: RANDY HAHN

## COMMERCIAL & RESIDENTIAL CONDUIT POLICY

### 3-PHASE SECONDARY CABINET DIMENSIONS (SMALL)

#### EXHIBIT 34

# OCALA ELECTRIC UTILITY STANDARDS

## SECONDARY CABINET

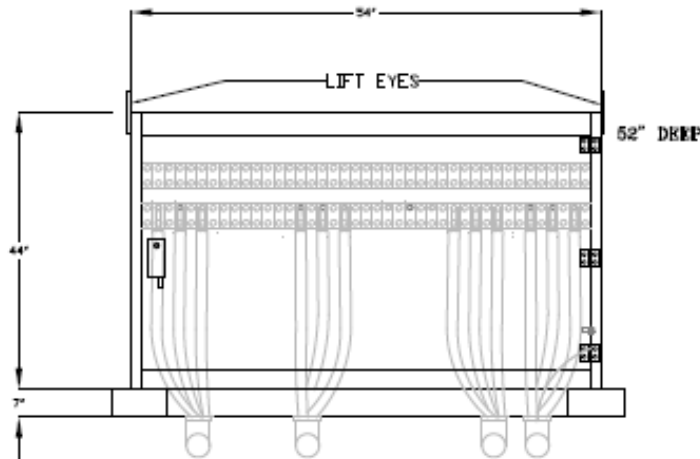

**FRONT VIEW**

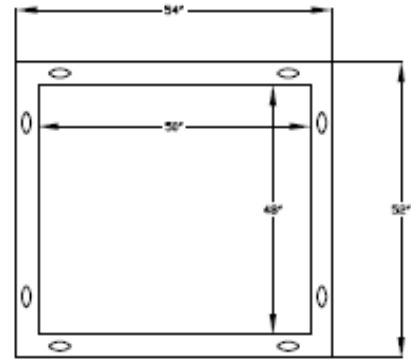

**BOTTOM VIEW**

**SV2111 ENCLOSURE, TERMINATION, SECONDARY 3Ø**

NO.	OUS STOCK NO.	DESCRIPTION	QTY	FERC
1	E14-24-0170	ENCLOSURE TERMINATION SECONDARY	1	367

### SECONDARY CABINET CONCRETE PAD DIMENSIONS

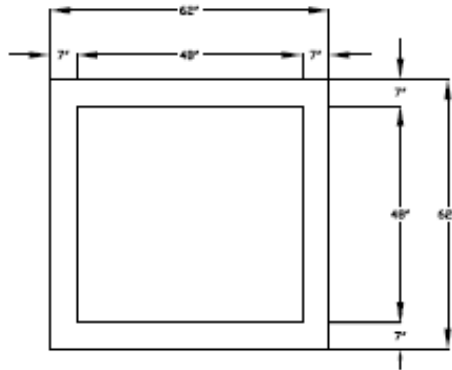

**PLAN VIEW**

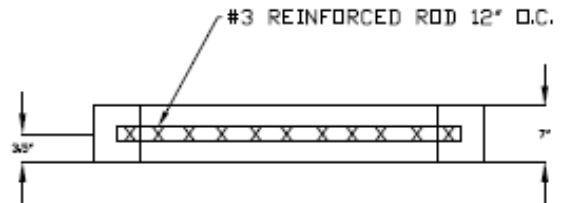

**NOTE: CONCRETE TO BE 3000 PSI AT 28 DAYS**

**ELEVATION VIEW**

**NOTES:**

1. THE SECONDARY CABINET PAD MUST FACE IN THE DIRECTION SPECIFIED BY THE ELECTRIC ENGINEERING DIVISION.
2. SHRUBS AND STRUCTURES MUST BE KEPT SIX FEET AWAY FROM ALL SIDES OF THE SECONDARY CABINET PAD.
3. THE SECONDARY CABINET PAD FORM MUST BE INSPECTED BY THE ELECTRIC ENGINEERING DIVISION, OEU OFFICE PHONE (352) 351-8820, PRIOR TO POURING CONCRETE. THE CONTRACTOR SHALL SCHEDULE THIS INSPECTION AT A MINIMUM OF TWENTY FOUR (24) HOURS IN ADVANCE.
4. PRE-FABRICATED CONCRETE PADS MAY BE PURCHASED FROM OUTSIDE VENDORS AS LONG AS THE PRE-FABRICATED PADS MEET UTILITY SPECIFICATIONS.
5. THE CABINET PAD SHOULD BE PLACED AT A DISTANCE TO ACCOMMODATE CONDUIT RADIUS-ELLS BETWEEN THE TRANSFORMER PAD AND THE CABINET PAD, BUT NO MORE THAN EIGHT (8) FEET FROM THE TRANSFORMER PAD.

REVISED DATE: AUGUST 23, 2023

REVISED BY: FRANK BROWN

APPROVED BY: RANDY HAHN

## COMMERCIAL & RESIDENTIAL CONDUIT POLICY

### 3-PHASE SECONDARY CABINET DIMENSIONS (LARGE)

#### EXHIBIT 35

# OCALA ELECTRIC UTILITY STANDARDS

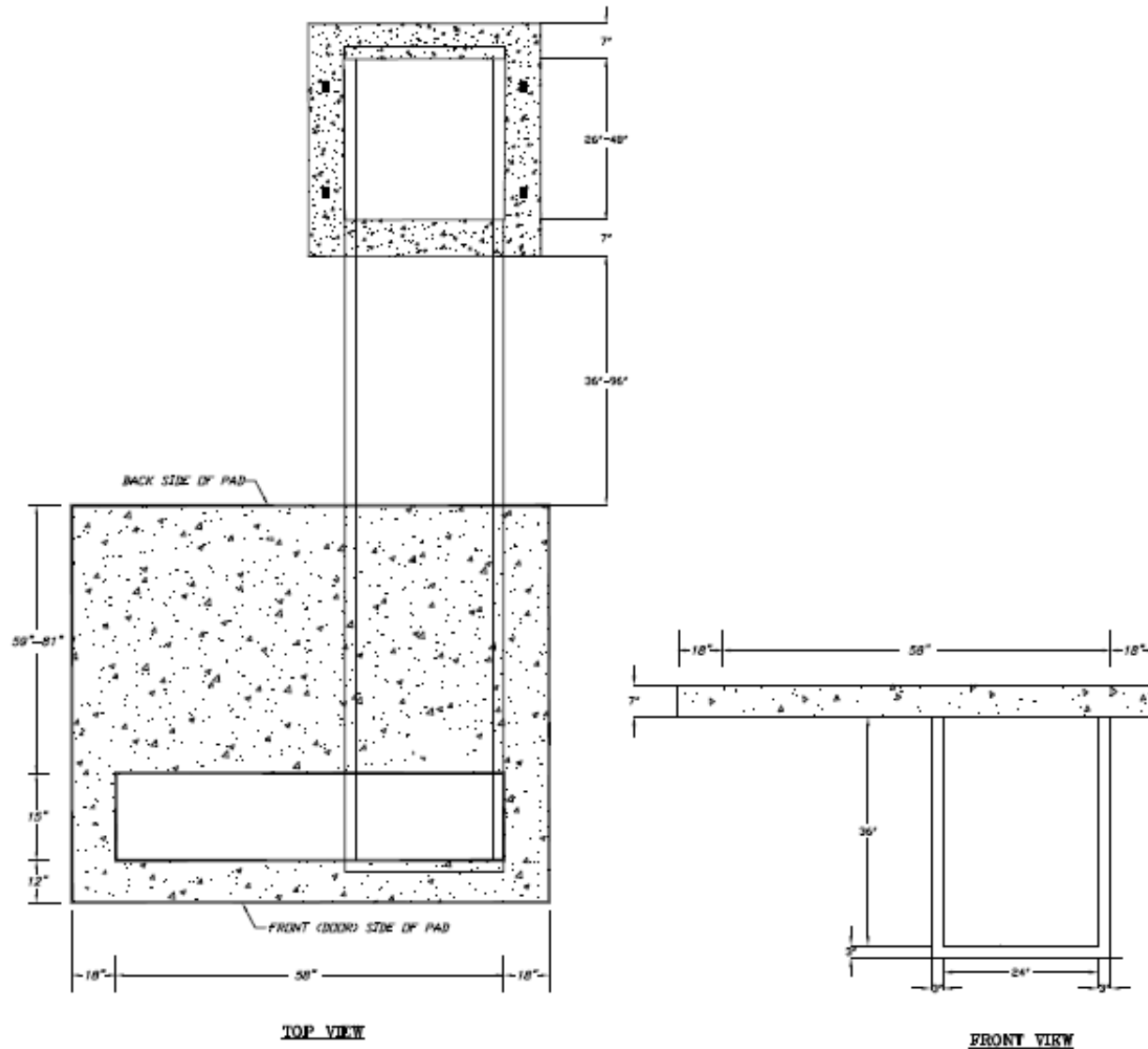

**NOTES:**

1. **THE SECONDARY CABINET TROUGH MUST BE CONSTRUCTED OF CONCRETE.**
2. **THE SECONDARY CABINET TROUGH MUST BE INSPECTED BY THE ELECTRIC ENGINEERING DIVISION, OEU OFFICE PHONE (352) 351-6620, PRIOR TO POURING CONCRETE. THE CONTRACTOR SHALL SCHEDULE THIS INSPECTION AT A MINIMUM OF TWENTY FOUR (24) HOURS IN ADVANCE.**

REVISED DATE: AUGUST 23, 2023

REVISED BY: FRANK BROWN

APPROVED BY: RANDY HAHN

## COMMERCIAL & RESIDENTIAL CONDUIT POLICY

### 3-PHASE TRANSFORMER & CABINET TROUGH (FRONT TO BACK) EXHIBIT 36

# OCALA ELECTRIC UTILITY STANDARDS

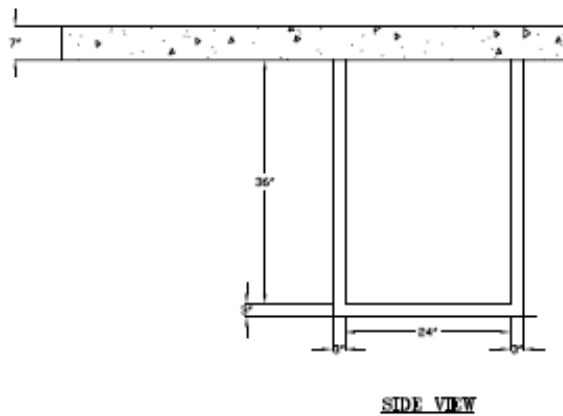
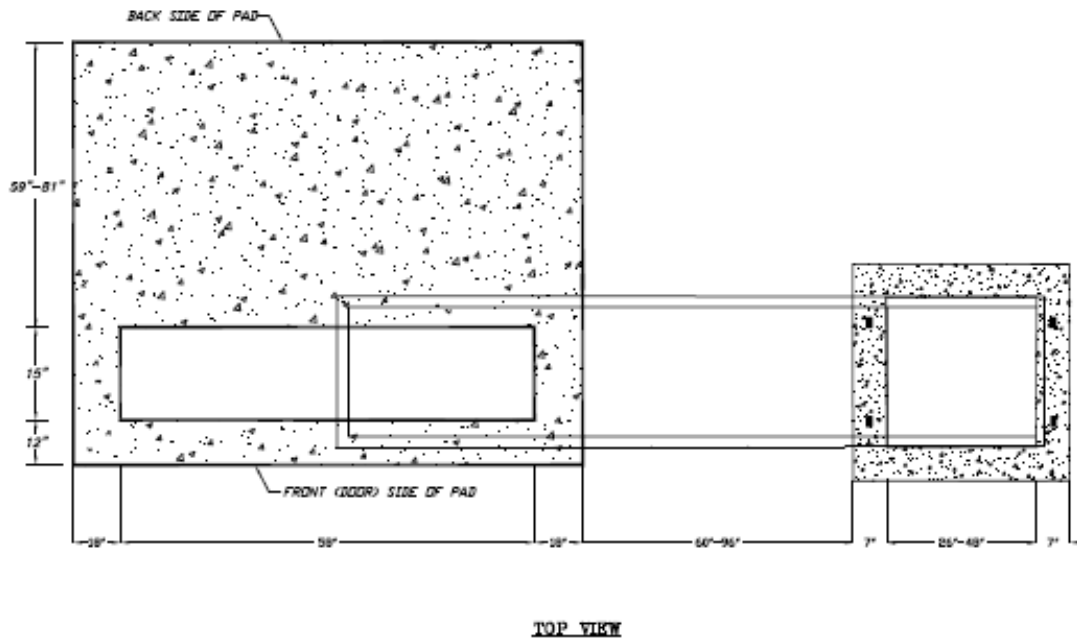

## NOTES:

1. THE SECONDARY CABINET TROUGH MUST BE CONSTRUCTED OF CONCRETE.
2. THE SECONDARY CABINET TROUGH MUST BE INSPECTED BY THE ELECTRIC ENGINEERING DIVISION, OEU OFFICE PHONE (352) 351-6620, PRIOR TO POURING CONCRETE. THE CONTRACTOR SHALL SCHEDULE THIS INSPECTION AT A MINIMUM OF TWENTY FOUR (24) HOURS IN ADVANCE.

REVISED DATE: AUGUST 25, 2023

REVISED BY: FRANK BROWN

APPROVED BY: RANDY HAHN

## COMMERCIAL & RESIDENTIAL CONDUIT POLICY

### 3-PHASE TRANSFORMER & CABINET TROUGH (SIDE TO SIDE)

EXHIBIT 37